

DME, DMS, DMM

Digital Dosing

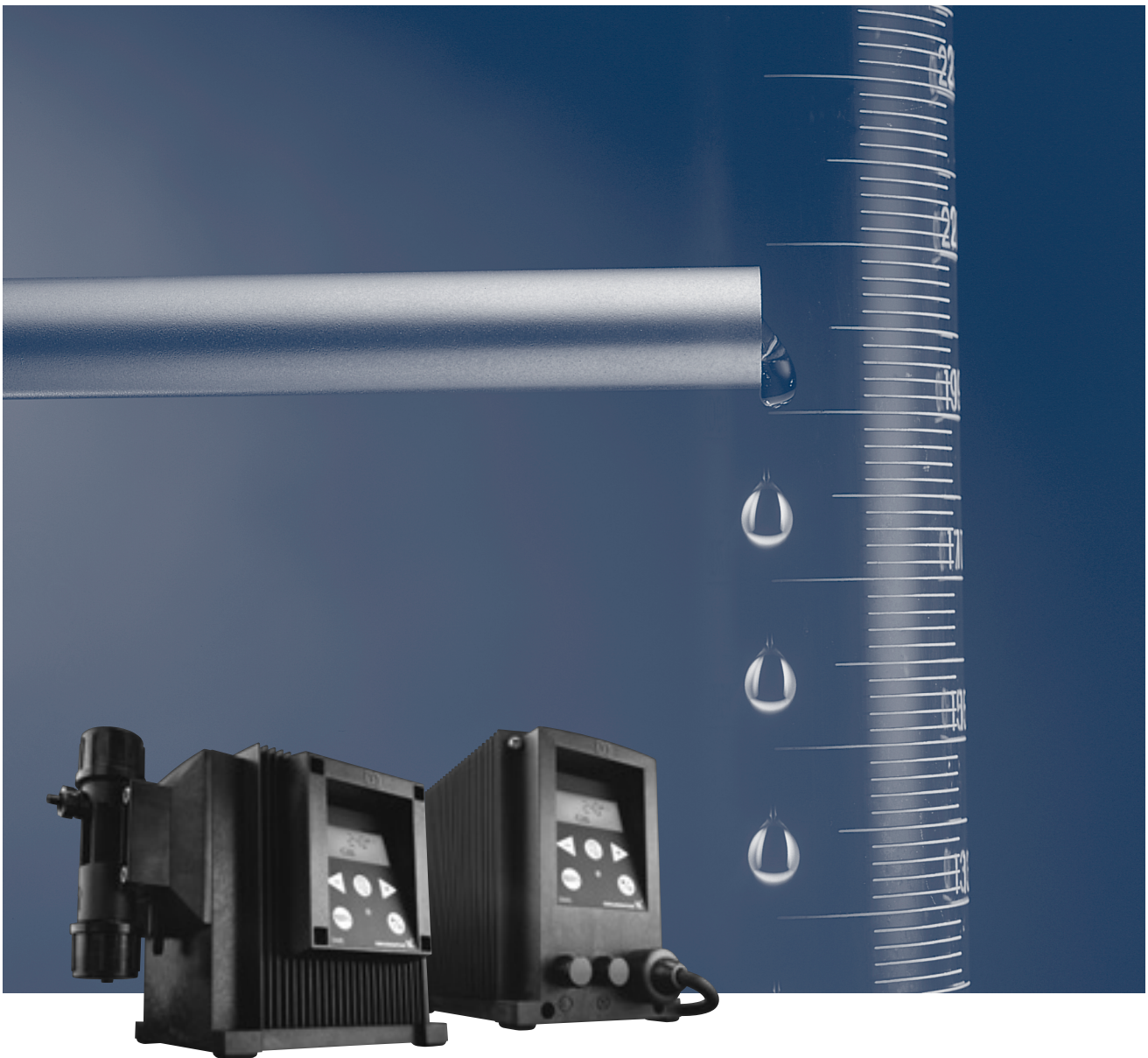

Contents

General information

Performance range	page	4
General information, DME, DMS	page	5
General information, DMM	page	5
Type key	page	6

Functions, DME, DMS

Overview	page	8
Capacity range	page	9
Capacity control	page	10
Control panel	page	11
Start/stop	page	12
Priming/venting	page	12
Level control	page	12
Indicator lights and alarm output	page	13
Fieldbus communication	page	13
Menu	page	14
Operating modes	page	15
Manual control	page	15
Setting range, DME	page	15
Setting range, DMS	page	15
Pulse control, DME, DMS-A	page	15
Setting range, DME	page	15
Setting range, DMS	page	15
Analog 4-20 mA control	page	16
Pulse-based batch control	page	17
Anti-cavitation	page	18
Calibration, DME, DMS	page	19
Counters	page	19
Languages	page	20
Maximum capacity limitation	page	21
Input setup	page	22
Units	page	22
Monitor setup	page	23
Lock	page	23
Default	page	23
Return	page	23

Performance curves/technical data, DME, DMS

DME	page	24
DMS-A, DMS-AR, DMS-B	page	26
DMS-D	page	28

Materials of construction, DME, DMS

Sectional drawing, DME	page	29
Sectional drawing, DMS	page	30
Wiring diagram	page	31
Dimensions, DME, DMS	page	32

Functions, DMM

Overview	page	33
Capacity control	page	34
Settings and operation	page	35
Stroke length setting	page	35
Control panel DMM-AR	page	35
Start/stop	page	35
Maximum permissible stroke frequency	page	35
Alarm output	page	36
Operating modes	page	36
Pulse and analog control	page	37

Materials of construction, DMM

Wiring diagram	page	38
Sectional drawing	page	39
Material specifications	page	40

Performance curves/technical data, DMM

Performance curves, DMM	page	41
Technical data	page	44
Dimensions	page	45

Accessories

Overview of accessories	page	46
Installation kit	page	47
Cable and plug kit	page	48
Tubing	page	48
Foot valve kit	page	49
Injection valve kit	page	50
Flow indicator	page	51
Multifunction valve	page	52
Dosing monitor	page	54
Adaptor connections	page	56
Level control unit	page	56
Rigid suction line	page	57
Back pressure and relief valve	page	58
Valve assembly	page	60
Automatic vent valve	page	63
Pulsation dampener	page	65
Priming aid	page	66
Tank	page	68
Wall bracket	page	70

Application profile

page	71
------	----

Mission

- to successfully develop, produce, and sell high quality pumps and pumping systems worldwide, contributing to a better quality of life and healthier environment



GBJ - Bjerringbro, Denmark



GMU - Fresno, California



GPU - Olathe, Kansas



GMX - Monterrey, Mexico



GPA - Allentown, Pennsylvania



GCA - Oakville, Ontario, Canada

- One of the 3 largest pump companies in the world
- World headquarters in Denmark
- North American headquarters in Kansas City - Manufacturing in Fresno, California
- 60 companies in 40 countries
- More than 10 million pumps produced annually worldwide
- North American companies operating in USA, Canada and Mexico
- Continuous reinvestment in growth and development enables the company to **BE** responsible, **THINK** ahead, and **INNOVATE**

Performance range

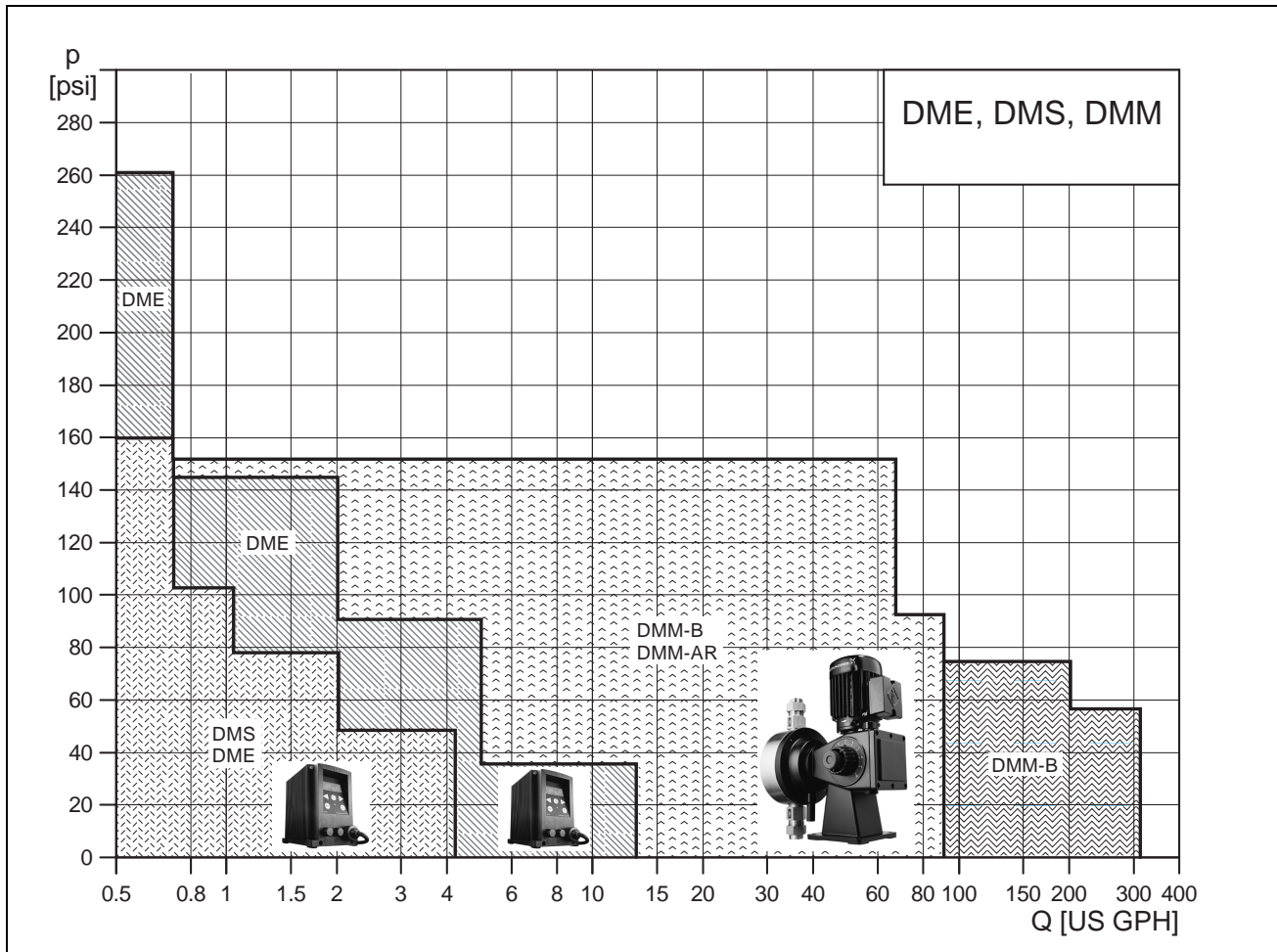

General Description

Grundfos dosing pumps install easily and offer user-friendly operation. The pumps ensure high accuracy as well as long life and flexibility. As they come in various materials, the pumps are resistant to most chemicals.

The varied pump range offers capacities from 0 to 313 gph as well as a number of control options, ranging from manual control to fieldbus control.

Thanks to the very large range of options, Grundfos dosing pumps are well suited for dosing many different liquids in applications such as water, wastewater, swimming pool and process water treatment, and washing systems.

Digital Dosing DME and DMS



Grundfos DME and DMS diaphragm pumps are the cornerstones of the Digital Dosing™ trademark. They combine all the features and functions of traditional dosing pumps, and make dosing so easy that precision will be something you can take for granted. The DME/DMS series covers an operating range of 0 to 12.6 gph at up to 261 psi back pressure.

The feature which makes Digital Dosing possible is continuous, direct contact between the motor and the diaphragm. The diaphragm is screwed into a crank shaft which is driven by the motor via a belt drive. This means that in contrast to traditional dosing pumps the position and, in the case of DME, the speed of the diaphragm is controlled right throughout every discharge/suction cycle.

The fundamental difference between DME and DMS pumps is the type of electronically controlled motor used to drive them. In the DMS series, a synchronous motor varies the stroke frequency to meet demand. In DME pumps, a stepper motor unique to Grundfos dosing pumps varies the stroke speed. The extended discharge phase of the DME gives better, more even, mixing.

The stepper motor in the DME opens up a number of exciting functions which will make your work easier and your results better. Grundfos' anti-cavitation function for high viscosity liquids is also based on the variable speed capacity. For both pump types, the dosage can be regulated manually, via analog signal (4-20 mA) or external pulses (ml/pulse only).

All pumps in the Digital Dosing range operate at maximum stroke length at all times so there is no need for adjustments. And because the stroke length is always full, the pump is less sensitive to gases released from liquids such as sodium hypochlorite and hydrogen peroxide. Any gas present is discharged immediately, maintaining precision with even the most difficult degassing liquids. A direct consequence of the innovative drive principle is that Digital Dosing pumps have high turn-down ratios and are therefore just as precise when dosing in very small amounts as at 100% capacity. This means that compared with solenoid dosing pumps, the entire range from 0 to 12.6 gph is covered by only five Grundfos models.

Features:

- Fewer models cover most needs
- Push-button display with easy-to-use menu
- Side or front-mounted control panel
- Counters
 - accumulated number of strokes
 - accumulated number of operating hours
 - accumulated times the pump is switched on
- High turndown ratio
 - DME is 1:1000
 - DMS is 1:100
- Switch-mode power supply (DME only) (100-240 V; 50-60 Hz)
- Integrated air bleed valve

DMM

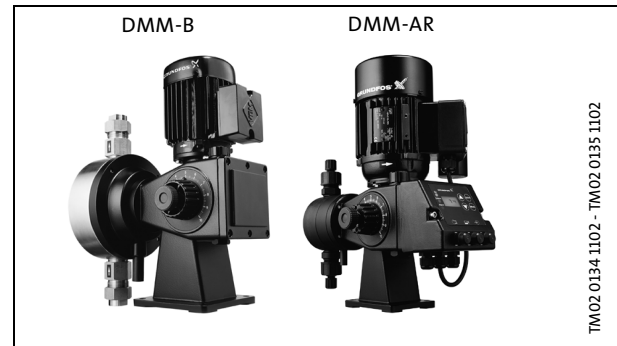

Grundfos DMM mechanical diaphragm dosing pumps are solid pumps with a proven track record of reliability in a wide variety of applications. In the context of the full range of Grundfos dosing pumps, the DMM complements the DME and DMS pumps with its high through-put. DMM pumps can dose up to 313 gph at up to 145 psi. Together with the complete range of pump accessories, the DMM can satisfy all your needs for high capacity dosing.

An external, fan-cooled motor, a single-stage worm gear, and an optional control unit combine to offer you a high level of control and flexibility over your dosing system. A long-life, PTFE-coated diaphragm and safe, reliable discharge and suction ball valves meet the highest standards in the dosing field. Spring-loaded check valves can be fitted for high viscosity liquids. The dosing head is designed for maximum resistance to and protection from corrosive liquids. A separation chamber behind the diaphragm insulates the pump unit from flooding in the unlikely event of a diaphragm failure. The dosing head is available in stainless steel or polypropylene.

The DMM-AR pump is equipped with an electronic motor control unit and a clear operating panel and display. Both the stroke length and frequency can be varied. On the DMM-B pump, only the stroke length is variable.

Type key

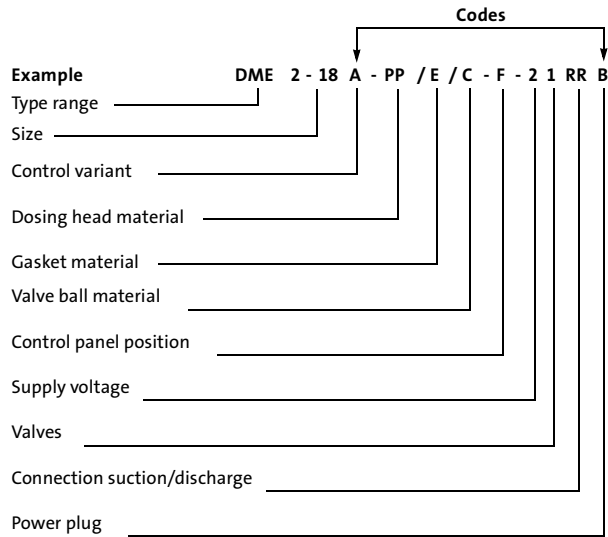

DME

Size	Capacity
2 - 18	.66 g/h, 261 psi
8 - 10	1.98 g/h, 145 psi
12 - 6	3.17 g/h, 87 psi
19 - 6	4.88 g/h, 90 psi
48 - 3	12.68 g/h, 38 psi

Control variant	
A	Standard
AR	Standard with alarm relay
AP	Standard + Profibus
AG	Standard + GENibus

Dosing head material	
PP	Polypropylene
PV	PVDF
SS	316 Stainless Steel

Gasket material	
E	EPDM
V	FKM

Valve ball material	
C	Ceramic
S	316 Stainless Steel

Control panel position	
F	Front fitted
S	Side fitted

Supply voltage	
2	1 x 120V, 60 Hz

Check valves	
1	Standard
2	Spring-loaded

Connections - suction/discharge	
T	Tubing 0.17" (ID) / 0.25" (OD)
R	Tubing 0.25" (ID) / 0.375" (OD)
S	Tubing 0.375" (ID) / 0.5" (OD)
V	Threaded NPT 0.25"***
Y	Threaded NPT 0.375"***

Note: All DME pumps are designed to operate at 1 x 100-240V, 50-60 Hz

Power plug	
B	USA, Canada 120V

*DME 19, 48 only, with SS head

**DME 2, 8, and 12 only, with SS head

DMS¹

Size	Capacity
2 - 11	.66 g/h, 160 psi
4 - 7	1.05 g/h, 102
8 - 5	1.98 g/h, 78 psi
12 - 3	3.17 g/h, 49 psi

Control variant	
A	Standard
AR	Standard with alarm relay
B	Basic
D	None

Dosing head material	
PP	Polypropylene
PV	PVDF
SS	316 Stainless Steel

Gasket material	
E	EPDM
V	FKM

Valve ball material	
C	Ceramic
S	316 Stainless Steel

Control panel position	
F	Front fitted
S	Side fitted (A and AR pumps only)
X	No control Panel (All D pumps only)

Supply voltage	
2	1 x 120V, 60 Hz

Check valves	
1	Standard
2	Spring-loaded

Connections - suction/discharge	
T	Tubing 0.17" (ID) / 0.25" (OD)
R	Tubing 0.25" (ID) / 0.375" (OD)
S	Tubing 0.375" (ID) / 0.5" (OD)
V	Threaded 0.25" - SS pumps only

Power plug	
B	USA, Canada 120V

¹Please see page 28 for DMS-D capacity.

DMM

Size	Capacity
4 - 10	1.3 g/h, 145 psi
8 - 10	2.4 g/h, 145 psi
15 - 10	4.8 g/h, 145 psi
23 - 10	6.1 g/h, 145 psi
48 - 10	15.3 g/h, 145 psi
72 - 10	19.0 g/h, 145 psi
110 - 5	33.8 g/h, 72 psi
155 - 4	42.3 g/h, 58 psi
160 - 10	49.4 g/h, 58 psi
210 - 10	66.0 g/h, 145 psi
290 - 8	92.5 g/h, 116 psi
440 - 5	139.5 g/h, 72 psi
640 - 5	202.9 g/h, 72 psi
990 - 4	313.8 g/h, 58 psi

Control variant	
AR	Standard + alarm relay
B	Basic

Dosing head material	
PP	Polypropylene
SS	316 Stainless Steel

Gasket material	
E	EPDM*
T	PTFE*
A	Centellen C TM **
H	CSM**

Valve ball material	
G	Glass*
S	316 Stainless Steel
C	Ceramic**
PV	PVDF***

Supply voltage	
2	1 x 120V, 60 Hz
5	3 x 230/460V, 60 Hz
7	3 x 575V, 60 Hz***

Check valves	
1	Standard
2	Spring-loaded

Control panel position	
F	Front fitted (AR)
X	No control panel (B)

Power plug	
B	USA, Canada 120V
X	No plug

Suction/discharge connections	
R	Tubing 0.25" (ID) / 0.375" (OD)
V	Threaded NPT 0.25" (DMM 4 to 72 only)
X	Threaded NPT 0.5" (DMM 110 to 290 only)

*Sizes DMM 4 to DMM 23 only

**Sizes DMM 48 to DMM 290 only

***Sizes DMM 440 to DMM 990 only

Overview of functions

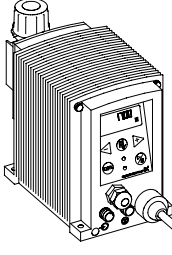
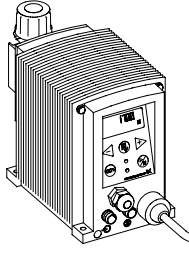
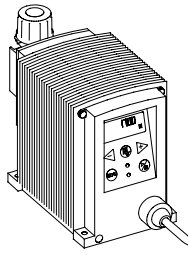
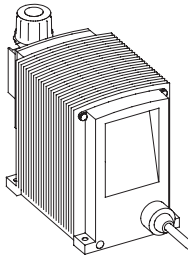
	DME	DMS		
		DMS-A	DMS-B	DMS-D
				
Capacity control				
Internal stroke frequency control	•	•	•	
Internal stroke speed control	•			
Control panel				
Capacity setting in US gallons, liters, milliliters	•	•	•	
Display with background light and soft-touch buttons	•	•	•	
Easy set-up menu with language options	•	•	•	
On/off button	•	•	•	
Priming button (temporary maximum speed)	•	•	•	
Green indicator light for operating indication	•	•	•	
Red indicator light for fault indication	•	•	•	
Lock function for control panel	•	•	•	
Side-fitted	•	•		
Front-fitted	•	•	•	
Operating modes				
Manual control	•	•	•	
External pulse control	•	•		
External analog 0/4-20 mA control	•	•		
Timer-based batch control	•			
Pulse-based batch control	•			
Functions				
Dosing monitoring	•	•		
Connection for dual-level control	•	•		
Calibration of pump to actual installation	•	•	•	
Anti-cavitation (reduced suction speed)	•			
Capacity limitation	•			
Counters for strokes, operating hours and power on/off	•	•	•	
Bus communication (variants AP and AG)	•			
Inputs/outputs				
Input for pulse control	•	•		
Input for analog 4-20 mA control	•	•		
Input for dual-level control or external start/stop	•	•		
Alarm relay output (variant AR)	•	•		
Power supply				
Switch-mode	•			

Capacity range

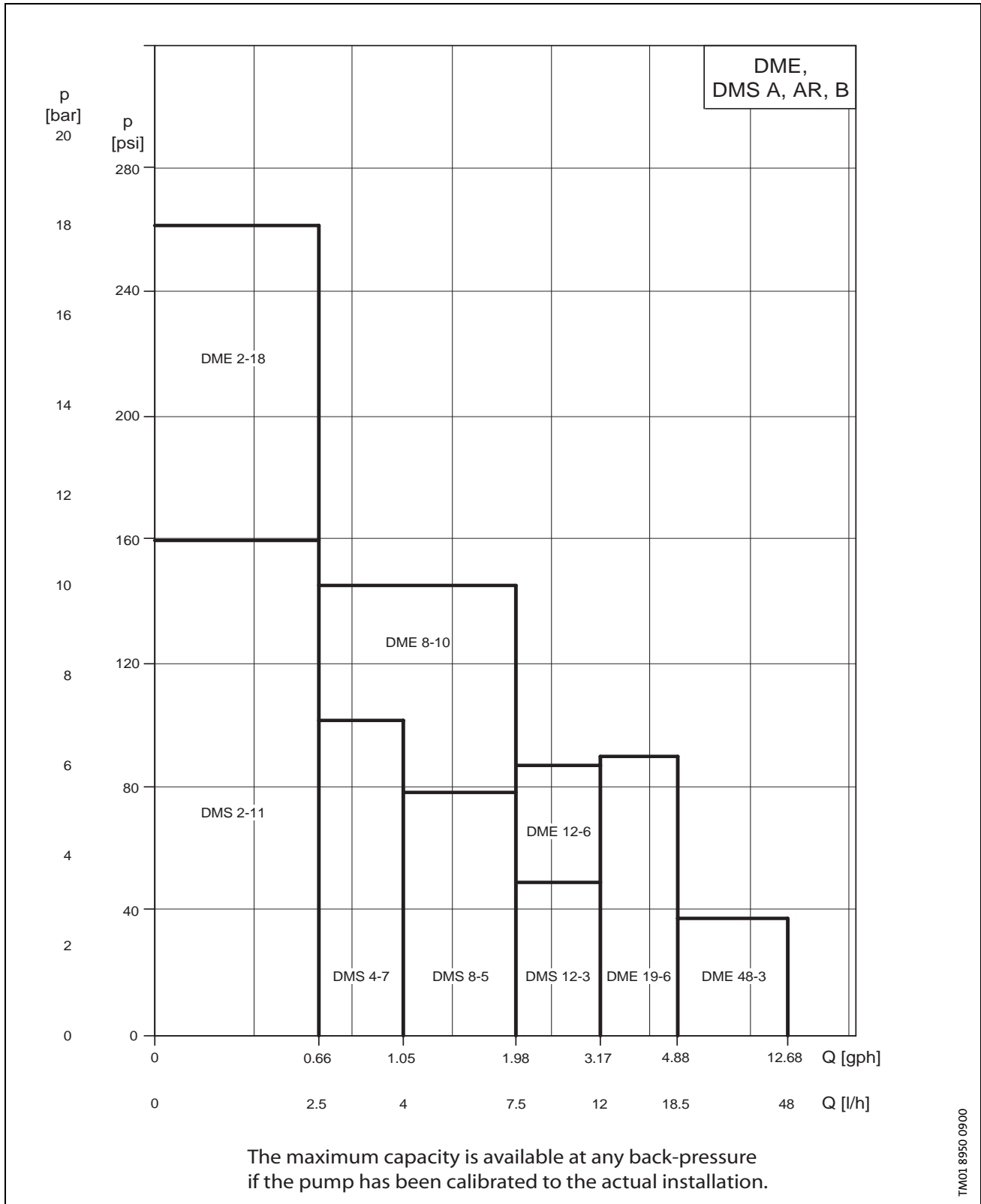

Capacity control, DME

The electronically controlled stepper motor of the DME pumps provides optimum control of the stroke speed. As shown in the figure below, the duration of each suction stroke is constant while the duration of each discharge stroke varies according to the capacity set, resulting in optimum discharge flow in any operating situation. The advantages are as follows:

- To obtain optimum accuracy, priming, and suction, the pump is always operating at full stroke length, irrespective of the capacity set.
- A capacity range of 1:1000 (turndown ratio).

- Even and constant dosing ensuring an optimum mixing ratio at the injection point.
- Significant reduction of pressure surges, preventing mechanical stress on diaphragm, tubes, connections and other dosing parts exposed to leakage and wear.
- The installation is less affected by long suction and discharge lines.
- Easier dosing of highly viscous and gas-containing liquids.

The optimum dosing control shown below takes place in any operating mode.

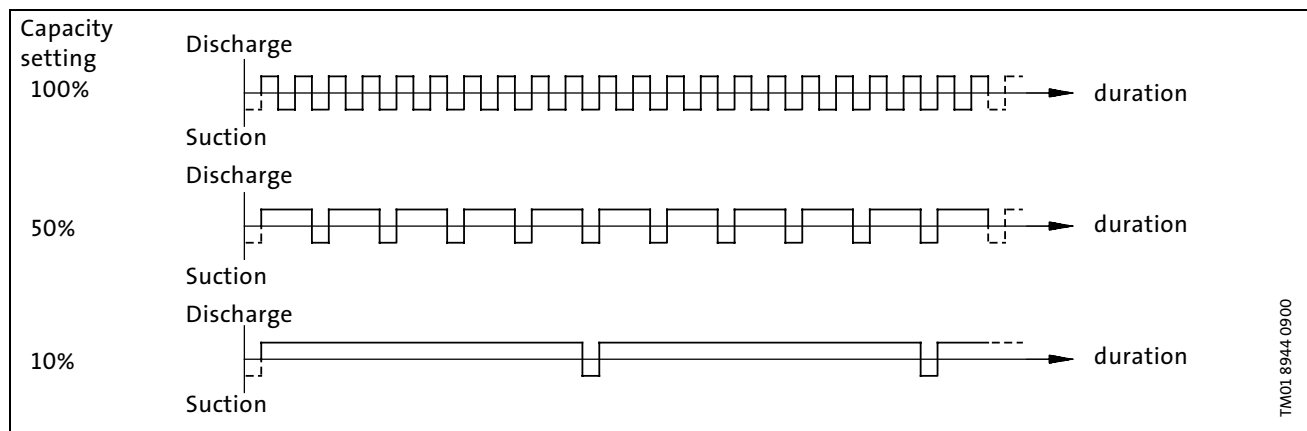

Capacity control, DMS

The electronically controlled synchronous motor of the DMS pumps offers almost the same advantages as those of DME pumps. As shown in the figure below, the suction and discharge stroke speeds are constant while the stroke frequency varies according to the capacity set. The sinusoidal movement of the diaphragm offers the following advantages:

- The pump is always operating at full stroke length, irrespective of the capacity set, for optimum accuracy, priming and suction.

- A capacity range of 1:100 (turndown ratio).
- Reduction of pressure surges, preventing mechanical stress on the diaphragm, tubes, connections and other dosing parts exposed to leakage and wear.
- The installation is less affected by long suction and discharge lines.
- Easier dosing of highly viscous and gas-containing liquids.

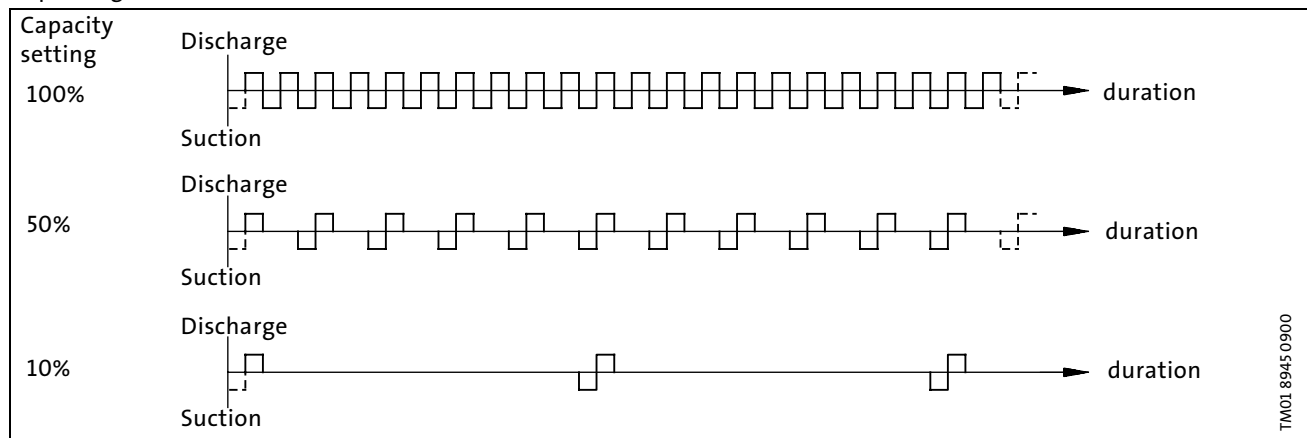

Control panel, DME and DMS

Setting and operation of DME and DMS pump functions are made on the control panel.

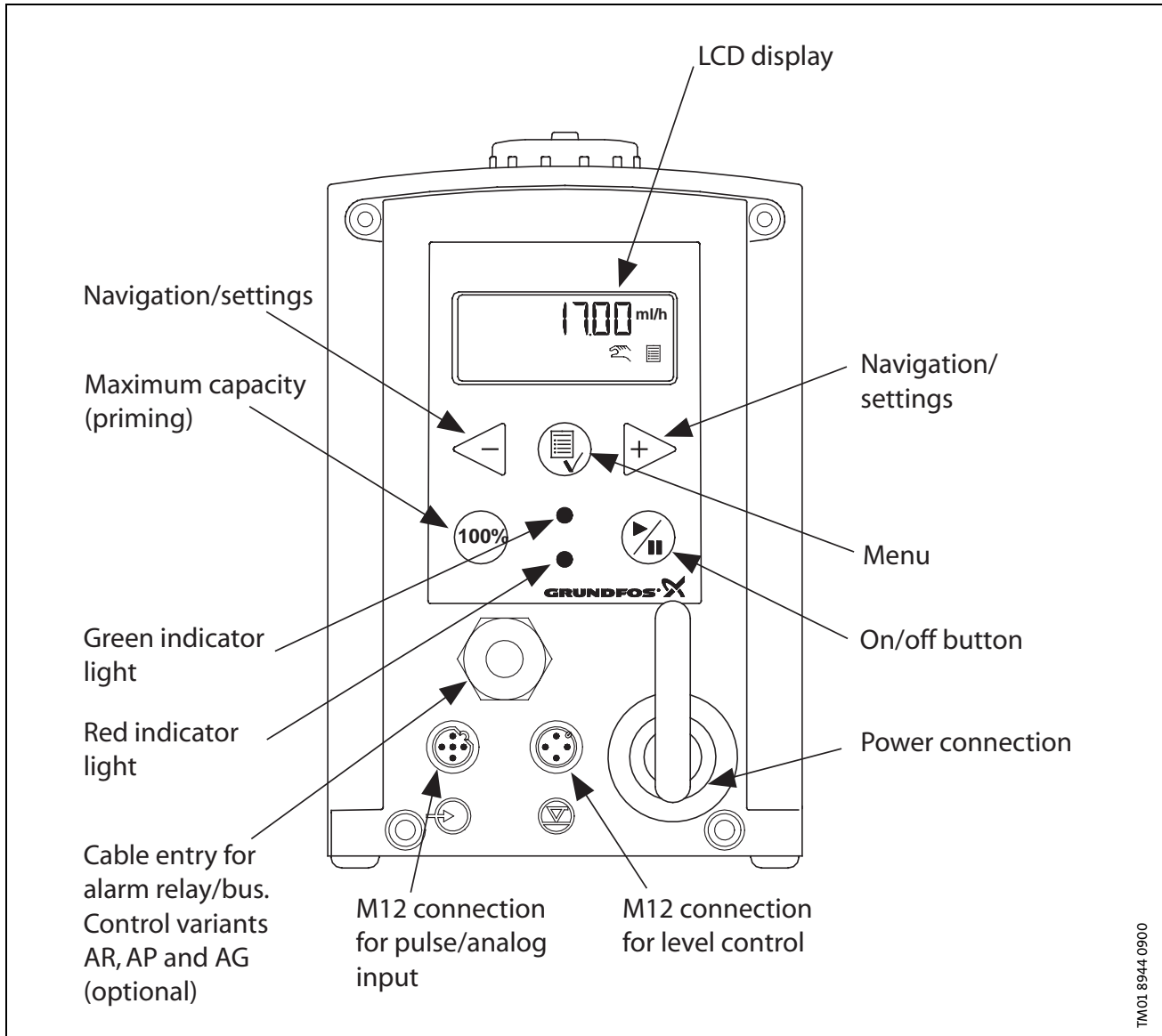

Start/Stop

The pump can be started/stopped in four different ways:

- by means of one of the external options (analog or pulse)
- locally on the pump control panel
- by means of an external on/off switch connected to the start/stop input
- by switching on/off the electrical supply.

Note: All settings are stored if the pump is switched off.



Priming/Venting of Pump

The DME and DMS dosing pumps are provided with an integrated vent valve to aid priming.

The pump control panel incorporates a 100% button. Press this button if the maximum pump capacity is required over a short period, e.g. during start-up. When the button is released, the pump automatically returns to the previous operating mode.

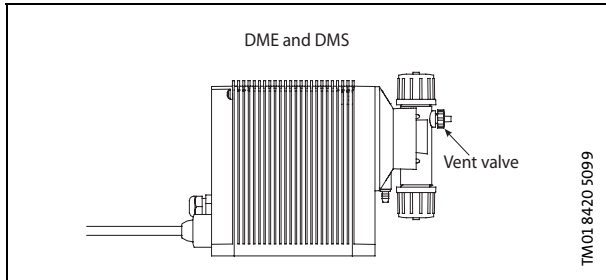
Note: Refer to the Installation and Operating instruction manual.



Note: When the buttons 100% and  are pressed simultaneously, the pump can be set to run for a specific number of seconds at maximum capacity. The remaining number of seconds will appear in the display. The maximum value is 300 seconds. Press  to stop the pump before the set time has passed.

Level control

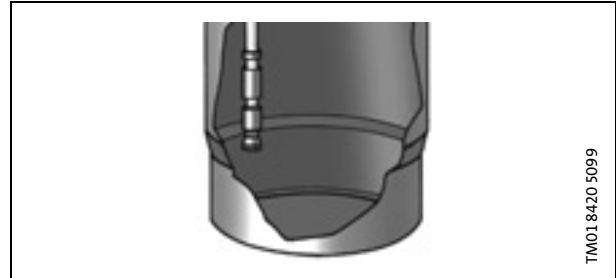

The pump can be fitted with a level control unit to monitor the chemical level in a tank (available on DME, DMS-A or DMS-AR).

The pump can react to two level signals. The pump will react differently, depending on the influence on the individual level sensors.

Level sensors	Pump reaction
Upper sensor activated	<ul style="list-style-type: none"> • Red indicator light is on. • Pump running. • Alarm relay activated.*
Lower sensor activated	<ul style="list-style-type: none"> • Red indicator light is on. • Pump stopped. • Alarm relay activated.*

* Control variant AR only.

Indicator lights and alarm output

The green and red indicator lights on the pump indicate operation or fault.

In control variant AR, the pump can activate an external alarm signal by means of a built-in alarm relay. The alarm signal is activated by means of an internal potential-free contact.

The functions of the indicator lights and the built-in alarm relay appear from the table below:

Condition	Green indicator light	Red indicator light	Display	Alarm output ¹
Pump running	On	Off	Normal Indication	
Set to stop	Flashing	Off	Normal Indication	
Pump fault	Off	On	EEPROM	
Supply failure	Off	Off	Off	
Pump running, low chemical level* ¹	On	On	Normal Indication	
Empty tank* ²	Off	On	Normal Indication	
Analog signal < 2 mA	Off	On	Normal Indication	
The pump is not dosing enough according to the signal from the dosing monitor* ³	On	On	-	
Overheated	Off	On	MAX TEMP	

*1.) Control variant AR only.

*2.) Requires connection to level sensors.

*3.) Requires dosing monitor function activated and a dosing monitor device connected to the pump.

Fieldbus communication

DME only

The pump is available with a built-in module for bus communication with GENibus (variant AG) or Profibus (variant AP) systems. These modules enable remote monitoring and setting via the fieldbus system.

Menu

The DME and DMS dosing pumps feature a user-friendly menu which is activated by pressing the  button. During start-up, all texts will appear in English language, but different languages can be chosen, see page 20.

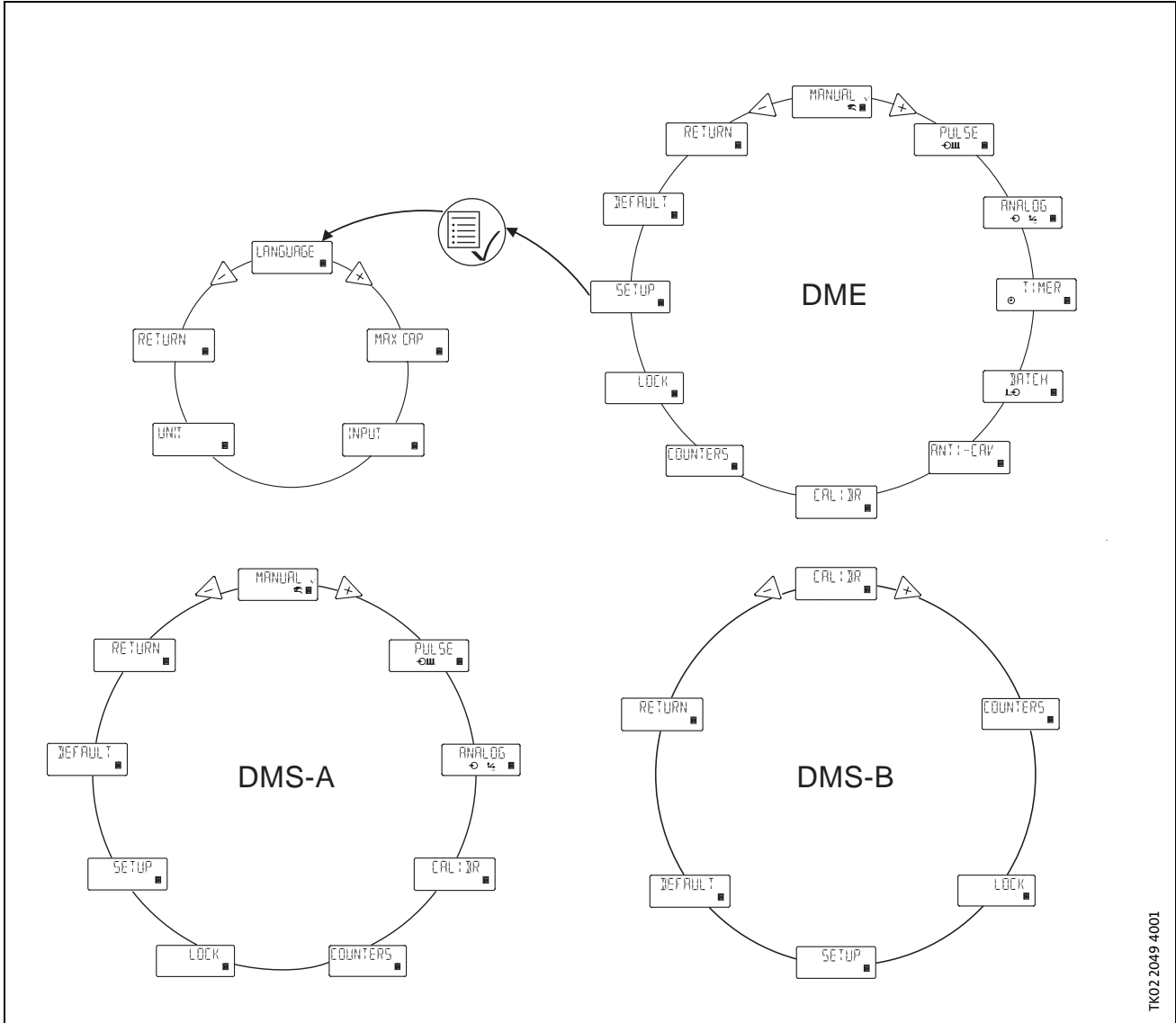



Operating modes

Manual control

The pumps are factory-calibrated at 50% of rated pressure. DME-2 and DMS-2 are, however, calibrated at 5 bar (72.5 psi). Water is used as pumped liquid during calibration.

When the "DEFAULT" function is chosen in the menu (resets all pump settings), the pump will return to its original factory-calibration value. As this value allows for the individual pump tolerances, it is unique for each individual pump.

The pump is constantly dosing according to the quantity set by means of the buttons  and .

It automatically changes over between the ml/h and l/h when measuring flow in metric units.

Setting range, DME:

Pump	U.S. gallons	Metric
DME 2 - 11	0.00066 - 0.66 (.47*) gph	2.5 ml/h - 2.5 (1.8*) l/h
DME 8 - 10	0.0020 - 1.98 (1.47*) gph	7.5 ml/h - 7.5 (5.6*) l/h
DME 12 - 6	0.0032 - 3.17 (2.37*) gph	12 ml/h - 12 (9*) l/h
DME 19 - 6	0.0049 - 4.88 (3.83*) gph	18.5 ml/h - 18.5 (14.5*) l/h
DME 48 - 3	0.0127 - 12.68 (9.77*) gph	48 ml/h - 48 (37*) l/h

* The figures in brackets indicate the maximum capacity when the anti-cavitation function is activated.

Setting range, DMS:

Pump	U.S. gallons	Metric
DMS 2 - 11	0.0066 - 0.66 gph	25 ml/h - 2.5 l/h
DMS 4 - 7	0.0105 - 1.05 gph	40 ml/h - 4.0 l/h
DMS 8 - 5	0.0198 - 1.98 gph	75 ml/h - 7.5 l/h
DMS 12 - 3	0.0317 - 3.17 gph	120 ml/h - 12 l/h

If the pump is operating with very high viscosities, the maximum capacity can be reduced after the calibration of the pump.

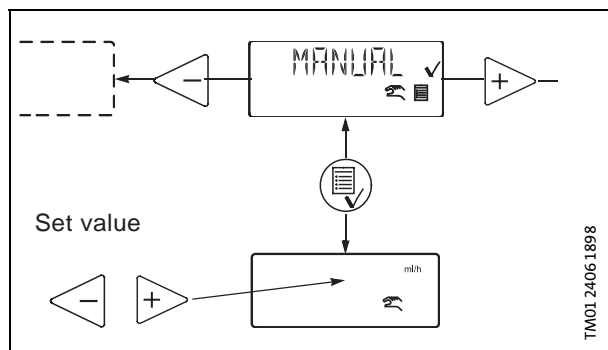

Pulse control

DME and DMS-A only

The pump is dosing according to an external pulse signal, e.g. a water meter with pulse output or a controller.

There is no direct relation between pulses and pump strokes. The pump automatically calculates its optimal speed to ensure the required quantity is dosed for each pulse. *The quantity to be dosed is set in ml/pulse only.* The pump adjusts its speed and/or stroke frequency according to two factors:

- frequency of external pulses and
- the set quantity per pulse.

When the quantity per pulse has been set and the  button is pressed, the display will show the actual capacity according to the above factors:

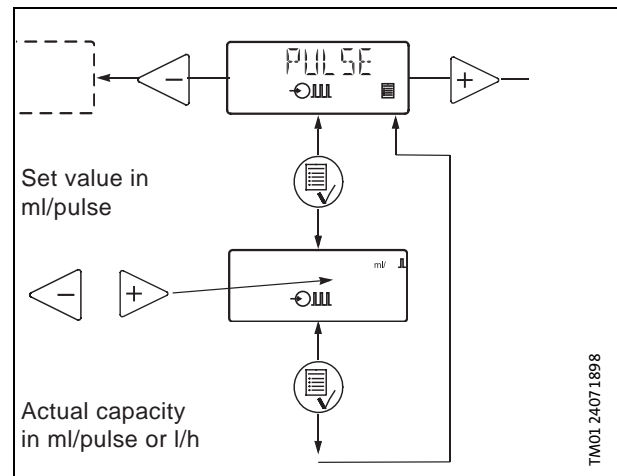

Setting range, DME:

Pump	Min. quantity [ml/pulse]	Max. quantity [ml/pulse]
DME 2 - 11	0.000018	4
DME 8 - 10	0.000069	15
DME 12 - 6	0.000111	24
DME 19 - 6	0.000204	37
DME 48 - 3	0.00530	96

Setting range, DMS

Pump	Min. quantity [ml/pulse]	Max. quantity [ml/pulse]
DMS 2 - 11	0.00230	50
DMS 4 - 7	0.00370	80
DMS 8 - 5	0.00695	150
DMS 12 - 3	0.01110	240

Analog 4-20 mA control

DME and DMS-A only

The pump is dosing according to an external analog signal. The dosed capacity is proportional to the input value in mA. See page 22 to change the output.

4-20 (default):	4 mA = 0%.
	20 mA = 100%.
20-4:	4 mA = 100%.
	20 mA = 0%.
0-20:	0 mA = 0%.
	20 mA = 100%.
20-0:	0 mA = 100%.
	20 mA = 0%.

The maximum capacity limitation, see page 21, will influence the capacity. 100% corresponds to the maximum capacity or the set capacity limitation.

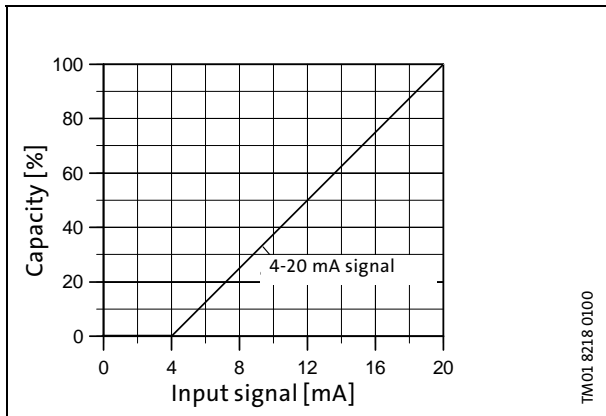

Selection of analog operation table:

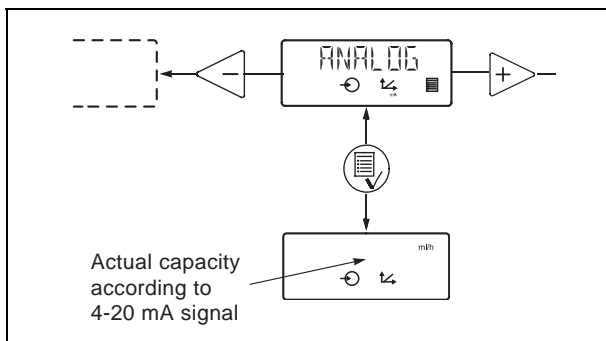

If 4-20 mA or 20-4 mA is selected and the signal falls below 2 mA, the pump will indicate fault. This situation occurs if the connection is interrupted, for instance, if the wire is damaged.

Pulse-based batch control

DME only

The pump is dosing the set quantity in batches at maximum capacity or the set capacity limitation.

The quantity is dosed every time the pump receives an external pulse. If the pump receives new pulses before the batch is completed, these pulses will be ignored.

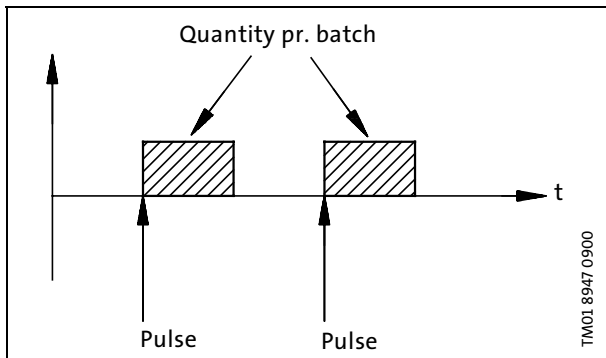
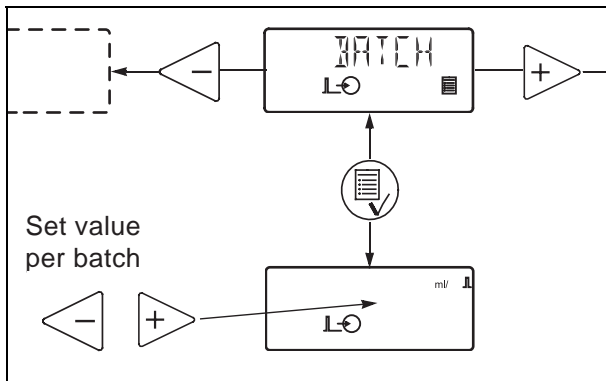

Setting range, DME:

Pump	Min. quantity [ml]	Max. quantity Gal. [l]
DME 2 - 11	0.23	1.32 [5]
DME 8 - 10	0.69	3.96 [15]
DME 12 - 6	1.11	6.34 [24]
DME 19 - 6	2.04	9.77 [37]
DME 48 - 3	5.30	25.36 [96]

The values are approximations. The minimum quantity will always correspond to one pump stroke at the given calibration value.

Anti-cavitation

DME only

The DME pump features an anti-cavitation function. When this function is selected, the pump's suction stroke characteristic is changed.

The anti-cavitation function is recommended with:

- high viscosity liquids,
- degassing liquids,
- long suction lines
- high suction lift.

The maximum capacity is reduced when this function is selected, see below.

DME 2 - 11	0.47 gph (1.8 l/h)
DME 8 - 10	1.47 gph (5.6 l/h)
DME 12 - 6	2.37 gph (9 l/h)
DME 19 - 6	3.83 gph (14.5 l/h)
DME 48 - 3	9.77 gph (37 l/h)

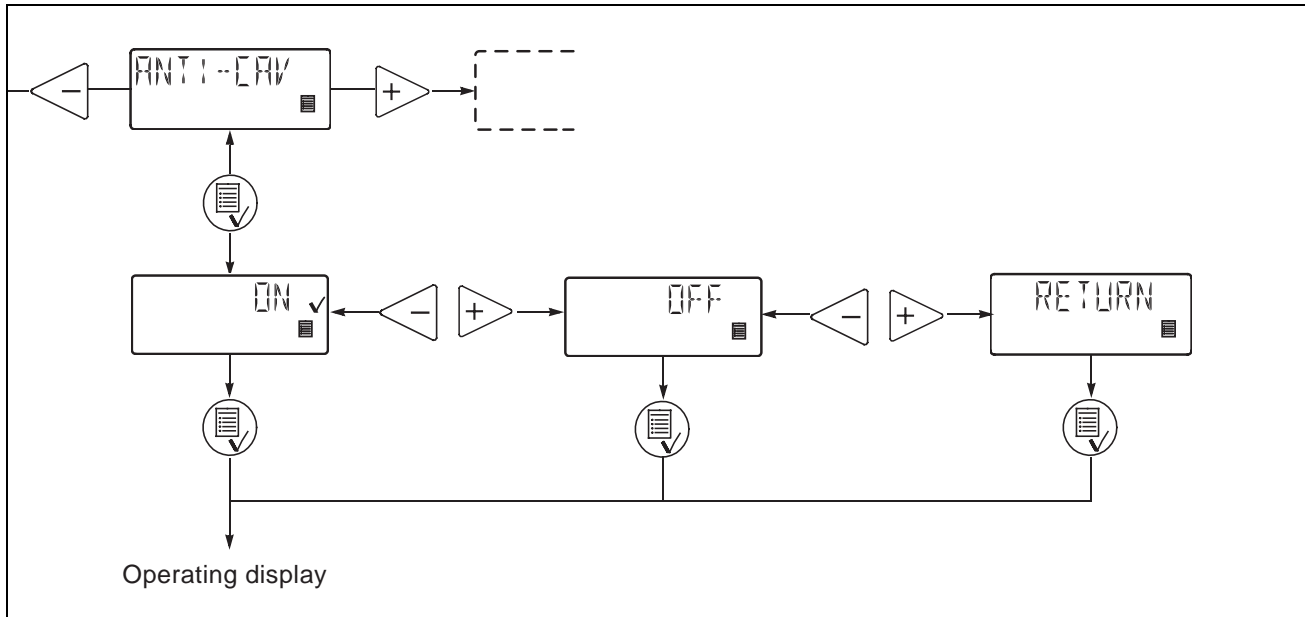

Calibration, DME and DMS

The pump can be calibrated after installation to ensure that the correct value (ml/h or l/h) appears in the display.

Several parameters may influence the pump performance, the most important being:

- system back pressure
- pump suction life
- viscosity of liquid.

The system back pressure is the pressure against which the pump must work, typically the pressure at the injection point. The suction lift is the geodetic height from a tank to the injection point.

If e.g. the viscosity is very high, the calibration of the pump can mean that the pump cannot reach its maximum performance.

DME and DMS pumps can be calibrated down to a value which reduces the maximum capacity to 50% (refer to Installation and Operating Manual).

Counters

The pump can display "non-resettable" counters for:

- **"Quantity"**
Accumulated dosed quantity in liters or US gallons.
- **"Strokes"**
Accumulated number of dosing strokes.
- **"Hours"**
Accumulated number of operating hours (power on).
- **"Power ON"**
Accumulated number of times the power supply has been switched on.

The counter values are updated when a button is activated, i.e. they always show the correct value.

The pump calculates the dosed volume by multiplying the number of strokes, with the calibration factor for one pump stroke, at the given time.

The stroke counter automatically changes to exponential recording when the number exceeds 99,999,999. The largest displayable value is 999,999E3, i.e. almost one billion strokes.

The time counter value is updated every two hours. If the pump is controlled by switching off the power, the value may thus not be updated. The "POWER ON" counter will, however, record the number of starts.

The "POWER ON" counter value is updated every time the pump is switched on

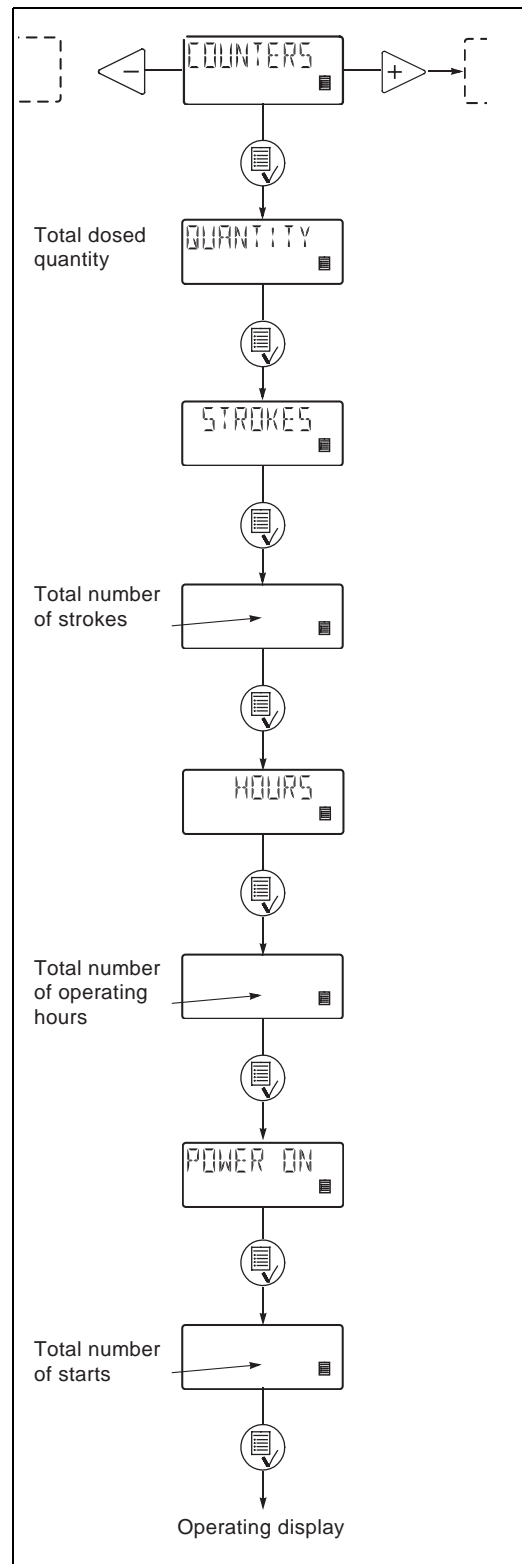

Languages

General Description

The setup submenus allow for setting or resetting the pump's basic functions.

Language

The display text can be displayed in one of the following languages chosen in the setup menu:

- English
- German
- French
- Dutch
- Spanish
- Italian
- Portuguese
- Danish
- Swedish
- Finnish
- Czeck
- Slovak
- Polish
- Russian

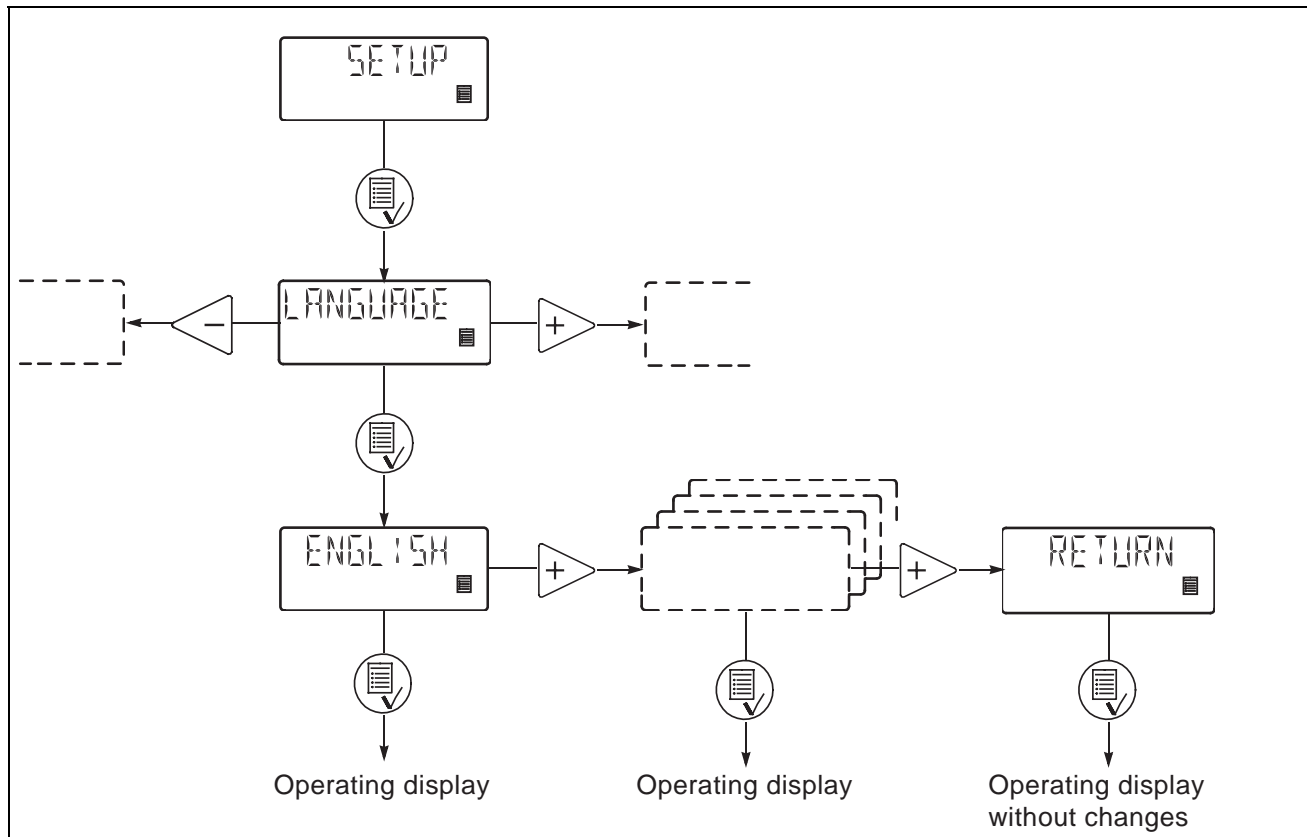

Maximum capacity limitation

DME only

This function allows the pump's maximum capacity to be changed. Displayed as **MAX CAP** in the **SETUP** menu, the pump cannot operate at a capacity higher than the one stated on the display. This does not apply to the priming button.

By means of this function, a large pump can be set to act as a much smaller pump. Together with the 1:1000 capacity range, the purposes of this function are:

1. To utilize the pump's smooth and even dosing characteristics at low capacities to achieve:
 - better chemical mixing
 - better dosing through long discharge tubes and
 - better dosing of high viscosity liquids.
2. To improve the dosing of gas-containing liquids. The reason for this is that the displaced (1) volume is much larger in relation to the non-displaced volume (2) in a large pump than in a small pump.

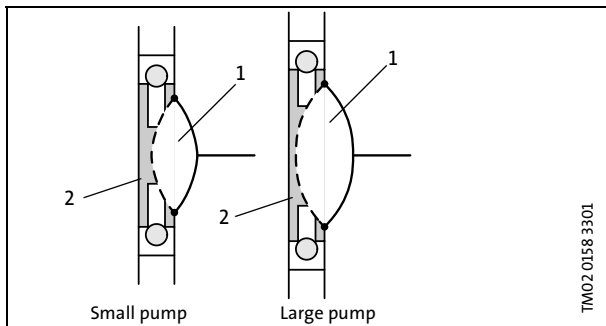

3. To cover several needs with just one pump size.
4. To adapt the pump to a 4-20mA signal control with 4mA corresponding to 0% and 20mA to the set maximum capacity.

This way it is possible for instance to use a larger pump, like a DME 48, for dosing a very small quantity of liquid without changing the input signal (see the following example).

Example:

A DME 48 is set to analog 4-20 mA control and receives a 12 mA input signal from a control instrument, resulting in a 50% output (according to the analog curve on page 16) and a capacity of 6.3 g/h.

A new situation occurs where it is only necessary to dose .5 g/h. The maximum capacity limitation is set to 1 g/h. The pump is still receiving a 12 mA signal resulting in a 50% output and a capacity of 0.5 g/h.

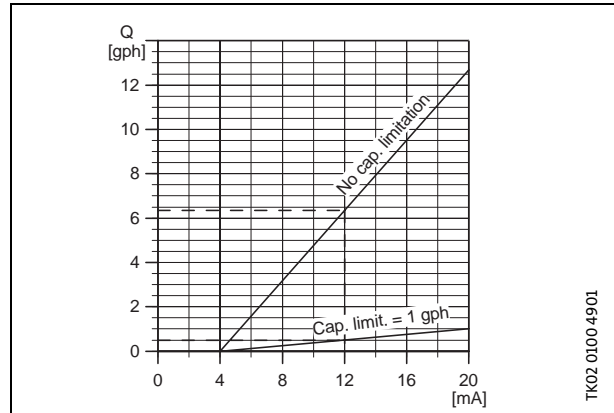

The maximum capacity limitation will also reduce the pump speed in timer-based batch control, pulse-based batch control and during calibration where the pump is usually operating at maximum capacity.

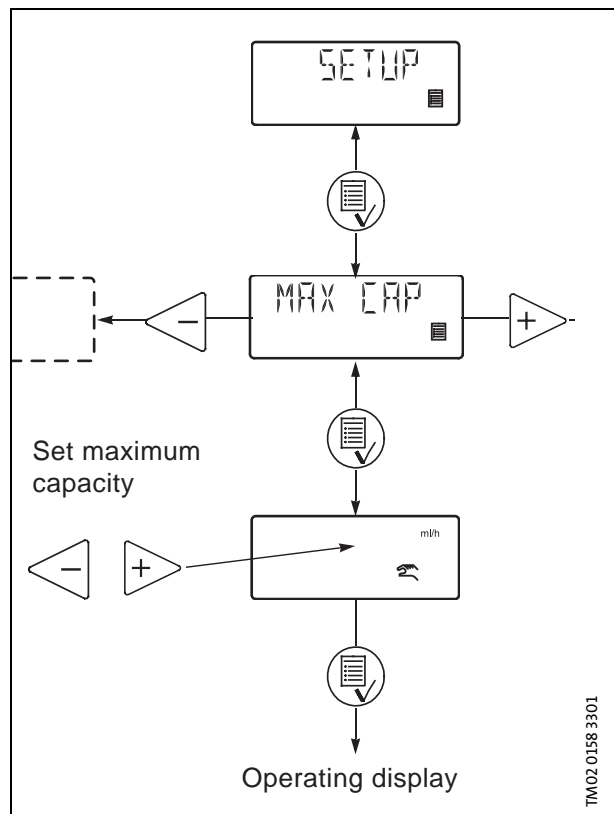

Input setup

Applies to all DME and DMS A(R).

Following settings of the input configuration is possible:

1. Level and stop inputs can be changed from NO (normally open) to NC (normally closed) function. If this change is made the inputs must be looped in normal operation.
2. The signal characteristics of the analog input can be selected between the following configurations:
 - 0 - 20 mA
 - 4 - 20 mA (default)
 - 20 - 0 mA
 - 20 - 4 mA

Change input for “low level” to dosing monitor input.

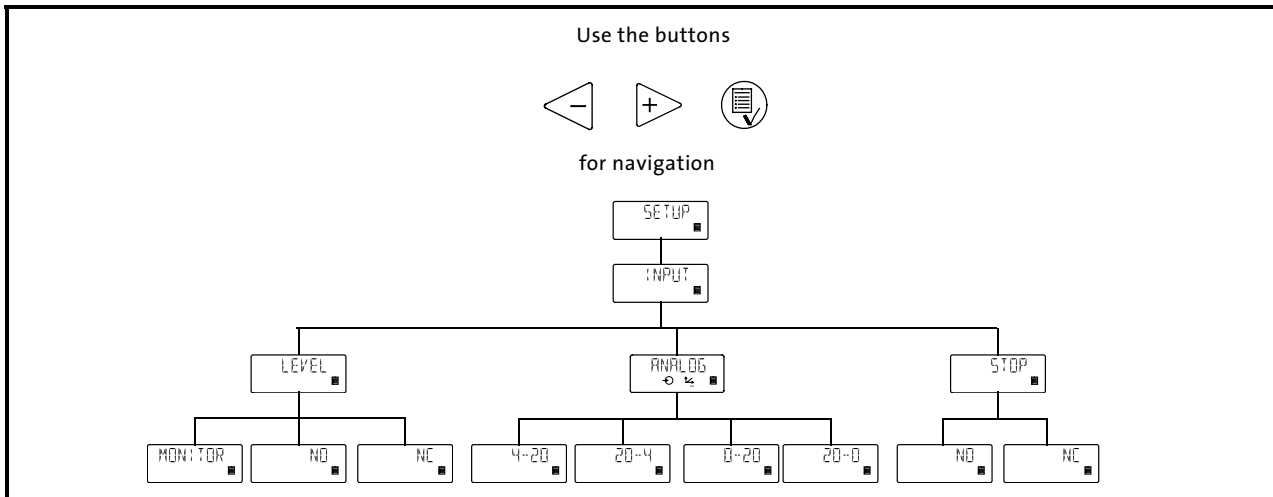

Units

Applies to all DME and DMS (except DMS-D)

It is possible to change display units between metric (liter/milliliter) and US liquid units (gallons/milliliter).

When **metric units** is selected:

- In manual and analog mode, the capacity is stated in liters per hour (l/h) or milliliters per hour (ml/h).
- In pulse mode the capacity is always set in ml/pulse. Capacity is shown in liters per hour (l/h) or milliliters per hour (ml/h).
- During calibration the setting is made in ml per 100 strokes.
- In batch and timer mode the capacity is stated in liters (l) or milliliters (ml).
- Under the VOLUME menu item in COUNTERS menu, the value is stated in liters.
- When **US units** is selected:
 - In manual and analog mode, the capacity is stated in gallons per hour (gph).

- In pulse mode the capacity is always set in ml/pulse. Capacity is shown in gallons per hour (gph).
- During calibration the setting is made in milliliters (ml) per 100 strokes.
- In batch and timer mode the capacity is stated in gallons (gal).

Under the VOLUME menu item in COUNTERS menu, the value is stated in gallons (gal).

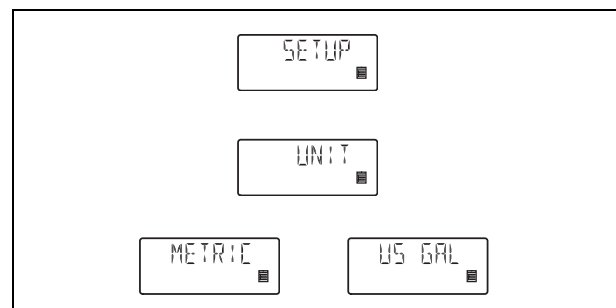

Monitor setup

Set level input to "MONITOR."

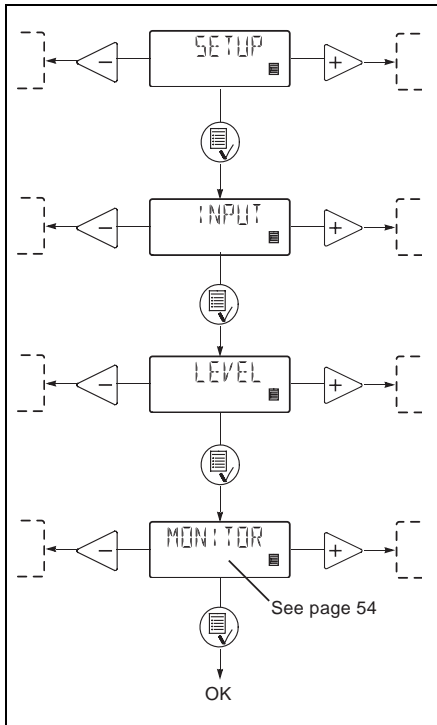

The dosing monitor is designed to monitor the dosing of liquids which may cause gas accumulation in the dosing head, thus stopping the dosing process even if the pump is still operating. See page 54 for more details.

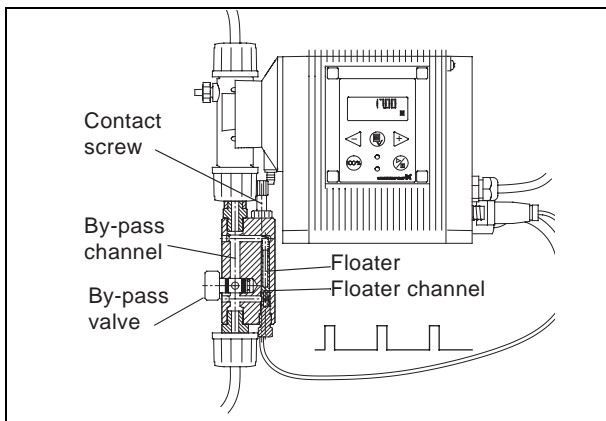

Lock

Applies to all DME and DMS

It is possible to lock the buttons on the control panel by means of a code to prevent incorrect operation of the pump. The locking function can be set to ON or OFF. See the pump installation and operating instructions for more information. The following operations are available even though the pumps is locked:

- Priming (100% button)
- Start/stop button+
- All external inputs

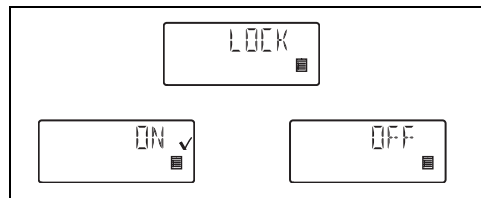

Default

When "DEFAULT" is activated, the pump will return to the factory settings.

Note: The calibration is also set back to the default setting. This means that a new calibration is required when the "DEFAULT" function has been used.

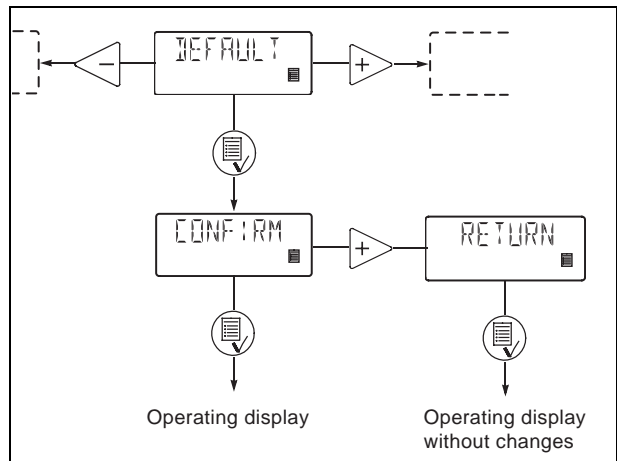

Return

The "RETURN" function makes it possible to return from any level in the menu to the operating display without changes after the menu functions have been used.

DME

Performance curve conditions:

Media: Water, 68°F (20°C)

Suction lift: 6.56 ft (2 m) for DME/DMS

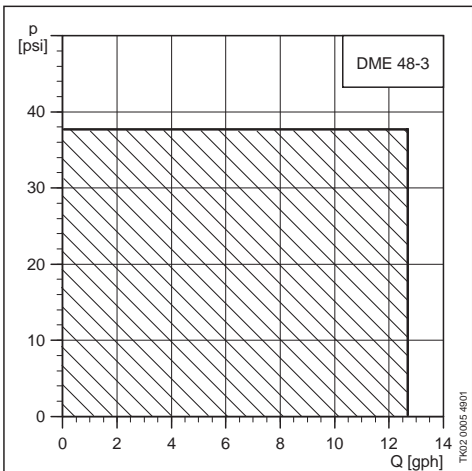
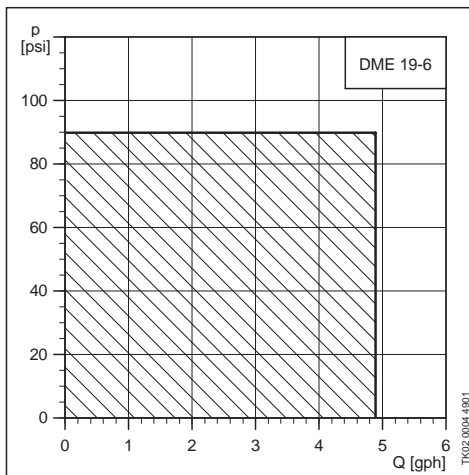
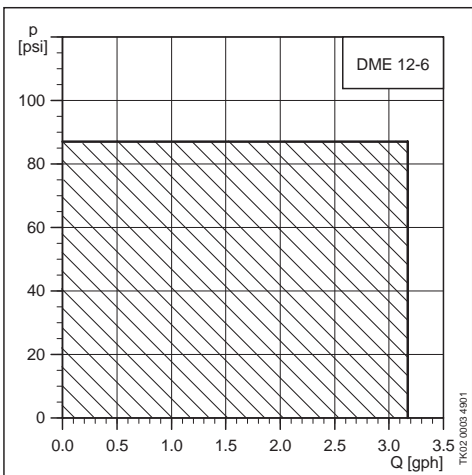
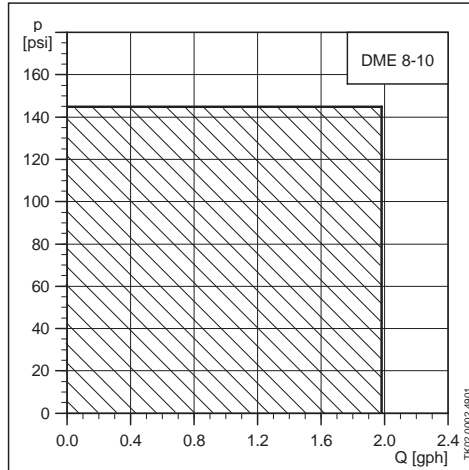
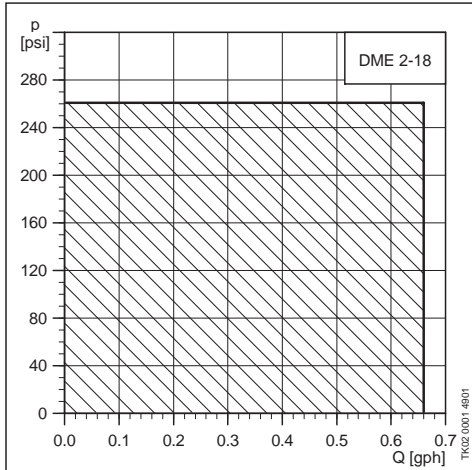

DME

Pump			DME 2-18	DME 8-10	DME 12-6	DME 19-6	DME 48-3
Operating data	Maximum capacity without anti-cavitation ★ ¹	[gph]	0.66	1.98	3.17	4.88	12.68
		[l/h]	2.5	7.5	12	18.5	48
	Maximum capacity with anti-cavitation ★ ¹	[gph]	0.47	1.47	2.37	3.83	9.77
		[l/h]	1.8	5.6	9	14.5	37
	Maximum pressure	[psi]	261	145	87	90	38
		[bar]	18	10	6	6.2	2.6
	Maximum stroke frequency ★ ² [stroke/min]		180	180	180	151	151
	Maximum suction lift during operation	[ft]	19.7				
		[m]	6				
	Maximum initial suction lift	[ft]	5.9	9.8	9.8	9.8	9.8
		[m]	1.8	3	3	3	3
	Maximum viscosity with spring-loaded valves ★ ³	[cp]	500	500	500	500	100
	Maximum viscosity without spring-loaded valves ★ ³	[cp]	200	200	200	200	100
	Maximum liquid temperature	[°F]	122				
		[°C]	50				
	Minimum liquid temperature	[°F]	32				
		[°C]	0				
Maximum ambient temperature	[°F]	113					
	[°C]	45					
Minimum ambient temperature	[°F]	32					
	[°C]	0					
Accuracy of repeatability		+/- 1%					
Weight and size	Weight	[lb]	5	5	5	7.5	7.5
		[kg]	2.2	2.2	2.2	3.4	3.4
	Diaphragm diameter	[in]	1.1	1.5	1.7	2.2	3.03
		[mm]	28	38	43.5	55	77
Electrical data	Supply voltage [V]		1 x 100-240V, 50-60 Hz				
	Maximum current consumption	[A] at 100 V	0.27			0.35	
		[A] at 230 V	0.16			0.26	
	Maximum power consumption P ₁	[W]	16.2			22.1	
	Enclosure class		IP 65				
Insulation class		F					
Signal input	Voltage to level sensor input	[VDC]	5				
	Voltage to pulse input	[VDC]	5				
	Minimum pulse-repetition period (from positive edge to positive edge)	[ms]	3.3				
	Impedance in analog 4-20 mA input	[Ω]	250				
	Maximum loop resistance in pulse signal circuit	[Ω]	350				
Maximum loop resistance in level signal circuit	[Ω]	350					
Signal output	Maximum load of alarm output, at ohmic load	[A]	2				
	Maximum voltage for alarm output	[V]	250				
Approvals		CE, UL, cUL					

★¹ At any back pressure if the pump is calibrated to the actual installation.

★² The maximum stroke frequency varies according to calibration.

★³ Maximum suction lift 3 ft (1 m).

DMS-A, DMS-AR, DMS-B

Performance curve conditions:

Media: Water, 68°F (20°C)

Suction lift: 6.56 ft (2 m) for DME/DMS

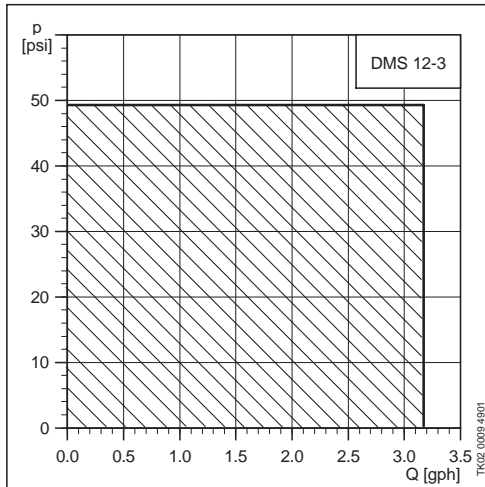
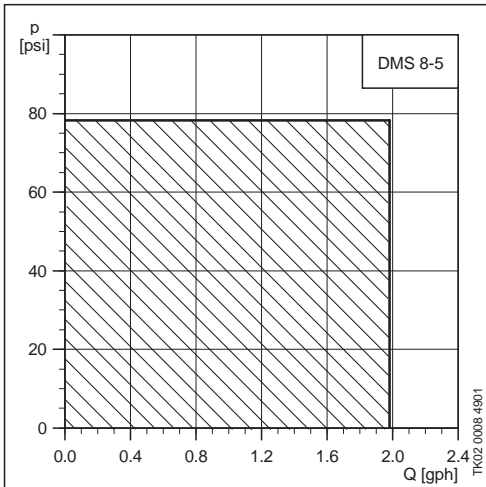
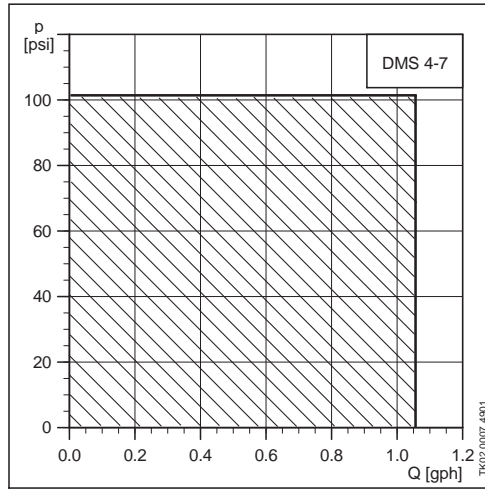
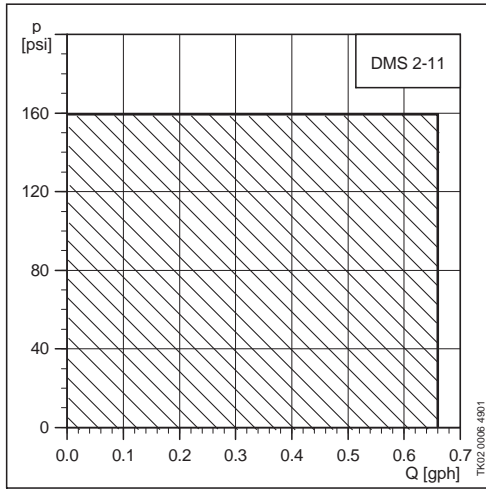

DMS-A, DMS-AR, DMS-B

Pump		DMS 2-11	DMS 4-7	DMS 8-5	DMS 12-3	
Operating data	Maximum capacity ★ ¹	[gph]	.66	1.05	1.98	3.17
		[l/h]	2.5	4	7.5	12
	Maximum pressure	[psi]	160	102	78	49
		[bar]	11	7	5.4	3.4
	Maximum stroke frequency ★ ²	[min]	180			
	Maximum suction lift during operation	[ft]	19.7			
		[m]	6			
	Maximum initial suction lift	[ft]	5.9	6.5	9.8	9.8
		[m]	1.8	2	3	3
	Maximum viscosity with spring-loaded valves ★ ³	[cp]	500			
	Maximum viscosity without spring-loaded valves ★ ³	[cp]	200			
	Maximum liquid temperature	[°F]	122			
		[C°]	50			
	Minimum liquid temperature	[°F]	32			
		[C°]	0			
Maximum ambient temperature	[°F]	113				
	[C°]	45				
Minimum ambient temperature	[°F]	32				
	[C°]	0				
Accuracy of repeatability		+/- 1%				
Weight and size	Weight	[lb]	5			
		[kg]	2.2			
	Diaphragm diameter	[in]	1.1	1.3	1.5	1.8
[mm]		28	32	38	42.5	
Electrical data	Supply voltage		1 x 120 V -12%/+8%, 60 Hz			
	Maximum current consumption	[A] at 120 V	0.17			
	Maximum power consumption P ₁	[W]	20			
	Enclosure class		IP 65			
	Insulation class		F			
Signal input	Voltage to level sensor input Must only be safety extra-low voltage	[VDC]	5			
	Voltage to pulse input	[VDC]	5			
	Minimum pulse repetition period	[ms]	3.3			
	Impedance in 4-20 mA analog input	[Ω]	250			
	Maximum loop resistance in pulse signal circuit	[Ω]	350			
	Maximum loop resistance in level signal circuit	[Ω]	350			
Signal output	Maximum load of alarm output at ohmic load	[A]	2			
	Maximum voltage for alarm output	[V]	250			
Approvals		CE, UL, cUL				

★¹ At any back pressure if the pump is calibrated to the actual installation.

★² The maximum stroke frequency varies according to calibration.

★³ Maximum suction lift 3 ft (1 m).

DMS-D

Pump		DMS 2-11	DMS 4-7	DMS 8-5	DMS 12-3	
Operating data	Maximum capacity ★ ¹	[gph]	1.03	1.82	2.75	4.33
		[l/h]	3.9	4	7.5	12
		% Deviation	+/- 20	+/- 18	+/- 8	+/- 6
	Maximum pressure	[psi]	160	101	78	49
		[bar]	11	7	5.4	3.4
	Maximum stroke frequency ★ ²	[min]	225			
	Maximum suction lift during operation	[ft]	19.7			
		[m]	6			
	Maximum initial suction lift	[ft]	5.9	6.5	9.8	9.8
		[m]	1.8	2	3	3
	Maximum viscosity with spring-loaded valves ★ ³	[cp]	500			
	Maximum viscosity without spring-loaded valves ★ ³	[cp]	200			
	Maximum liquid temperature	[°F]	122			
		[C°]	50			
	Minimum liquid temperature	[°F]	32			
		[C°]	0			
Maximum ambient temperature	[°F]	113				
	[C°]	45				
Minimum ambient temperature	[°F]	32				
	[C°]	0				
Accuracy of repeatability		+/- 1%				
Weight and size	Weight [lb (kg)]	5 (2.3)				
	Diaphragm diameter	[in]	1.1	1.3	1.5	1.8
[mm]		28	32	38	42.5	
Electrical data	Supply voltage	1 x 120 - 12%/+8%, 60 Hz				
	Maximum current consumption	[A] at 120 V	0.17			
	Maximum power consumption P ₁	[W]	20			
	Enclosure class		IP 65			
Insulation class		F				

★¹ At any back pressure if the pump is calibrated to the actual installation.

★² The maximum stroke frequency varies according to calibration.

★³ Maximum suction lift 3 ft (1 m).

Sectional drawing, DME

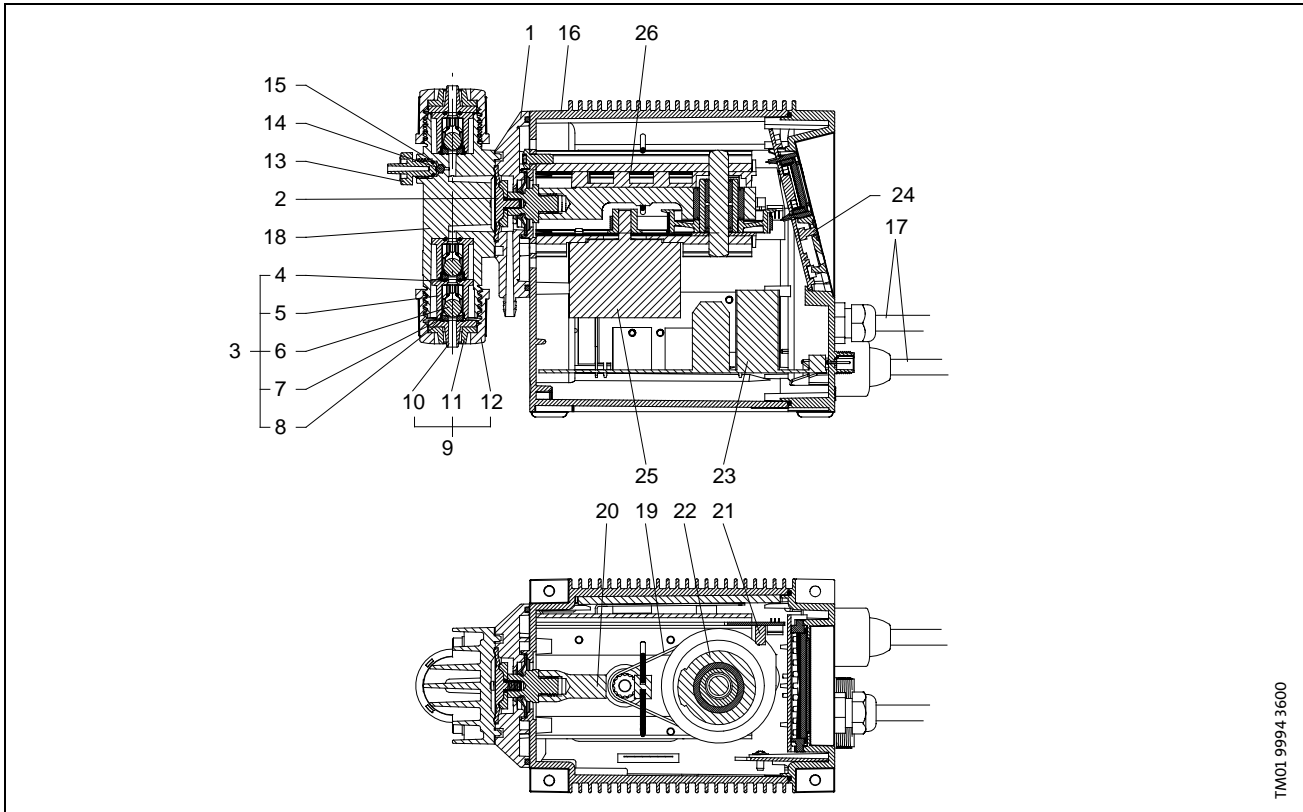

TM01 9994 3600

Construction

The DME pump is motor-driven diaphragm pump consisting of the following main parts:

Dosing head: Designed with a minimum of clearance space to optimize the priming and deaerating capabilities. The dosing head has built-in valve housings.

Valves: Double-ball suction valve and single-ball discharge valve. Spring-loaded valves are available as an option.

Vent valve: For priming and deaerating with connection for .17" x .25" tubing.

Connections: Sturdy and easy-to-use connections for various sizes of tubing and pipe thread.

Diaphragm: PTFE-coated, textile-reinforced EPDM diaphragm designed for long life.

Backplate: With separation chamber, safety diaphragm and drain hole.

Drive unit: With diaphragm connecting rod, crank, belt-drive and stepper motor, all mounted on a sturdy frame.

Cabinet: Containing drive unit, electronics, control panel and various electrical connections.

Material specification

Pos.	Description	Material options
1	Backplate	PPO 20% glass fiber
2	Diaphragm	Textile-reinforced EPDM, PTFE-coated
3	Valve assembly	includes items 4 -8
4	O-ring	EPDM/FKM
5	Valve casing	PP/PVDF/316 stainless steel
6	Valve ball	Ceramic/316 stainless steel
7	Valve seat disk	EPDM/FKM
8	Valve seat ring	PP/PVDF/316 stainless steel
9	Connection assembly	Includes 10, 11, 12
10	Cone/thread piece	PP/PVDF/316 stainless steel
11	Clamping ring	PP/PVDF
12	Union nut	PP/PVDF/316 stainless steel
13	Vent valve screw	PP/PVDF
14	Vent valve ball	Ceramic/316 stainless steel
15	Vent valve O-ring	EPDM/FKM
16	Cabinet	PPO 20% glass fiber
17	Power/alarm cable	Rubber
18	Dosing head	PP/PVDF/316 stainless steel
19	Drive belt	Rubber, polyamide-reinforced
20	Connecting rod	Steel
21	Origo sensor	-
22	Crank shaft	Steel
23	Power PCB	-
24	Operation PCB	-
25	Stepper motor	-
26	Drive frame	Aluminium

Sectional drawing, DMS

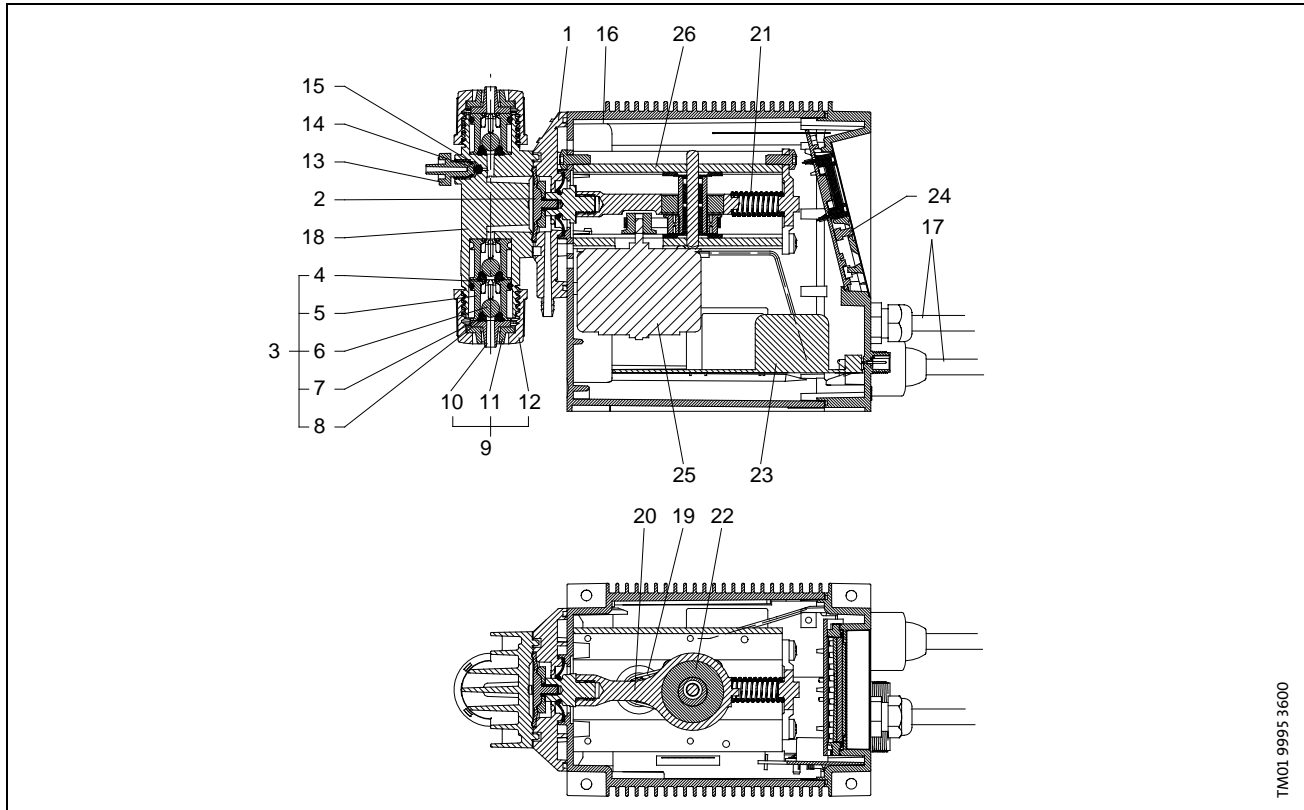

TM01 9995 3600

Construction

The DMS pump is motor-driven diaphragm dosing pump consisting of the following main parts:

Dosing head: Designed with a minimum of clearance space to optimize the priming and deaerating capability. The dosing head has built-in valve housings.

Valves: Double-ball suction valve and single-ball discharge valve. Spring-loaded valves are available as an option.

Vent valve: For priming and deaerating with connection for .17" x .25" tubing.

Connections: Sturdy and easy-to-use connections for various sizes of tubing, pipe threads.

Diaphragm: PTFE-coated, textile-reinforced EPDM diaphragm designed for long life.

Backplate: With separation chamber, safety diaphragm and drain hole.

Drive unit: With diaphragm connecting rod, crank, belt-drive and synchronous motor, all mounted on a sturdy frame.

Cabinet: Containing drive unit, electronics, control panel and various electrical connections (DMS-A).

Material specification

Pos.	Description	Material options
1	Backplate	PPO 20% glass fiber
2	Diaphragm	Textile-reinforced EPDM, PTFE-coated
3	Valve assembly	includes items 4 - 8
4	O-ring	EPDM/FKM
5	Valve casing	PP/PVDF/Stainless steel
6	Valve ball	Ceramic/316 stainless steel
7	Valve seat disk	EPDM/FKM
8	Valve seat O-ring	PP/PVDF/316 stainless steel
9	Connection assembly	-
10	Cone/thread piece	PP/PVDF/316 stainless steel
11	Clamping ring	PP/PVDF
12	Union nut	PP/PVDF/316 stainless steel
13	Vent valve screw	PP/PVDF
14	Vent valve ball	Ceramic/316 stainless steel
15	Vent valve O-ring	EPDM/FKM
16	Cabinet	PPO 20% glass fibre
17	Power/alarm cable	Rubber
18	Dosing head	PP/PVDF/316 stainless steel
19	Drive belt	Rubber, polyamide-reinforced
20	Connecting rod	Steel
21	Dosing stroke auxiliary spring	-
22	Crank shaft	Steel
23	Power PCB	-
24	Operation PCB	-
25	Synchronous motor	-
26	Drive frame	Aluminium

Wiring diagram

DME and DMS-A, AR

See pages 25 and 27 for input/output data.

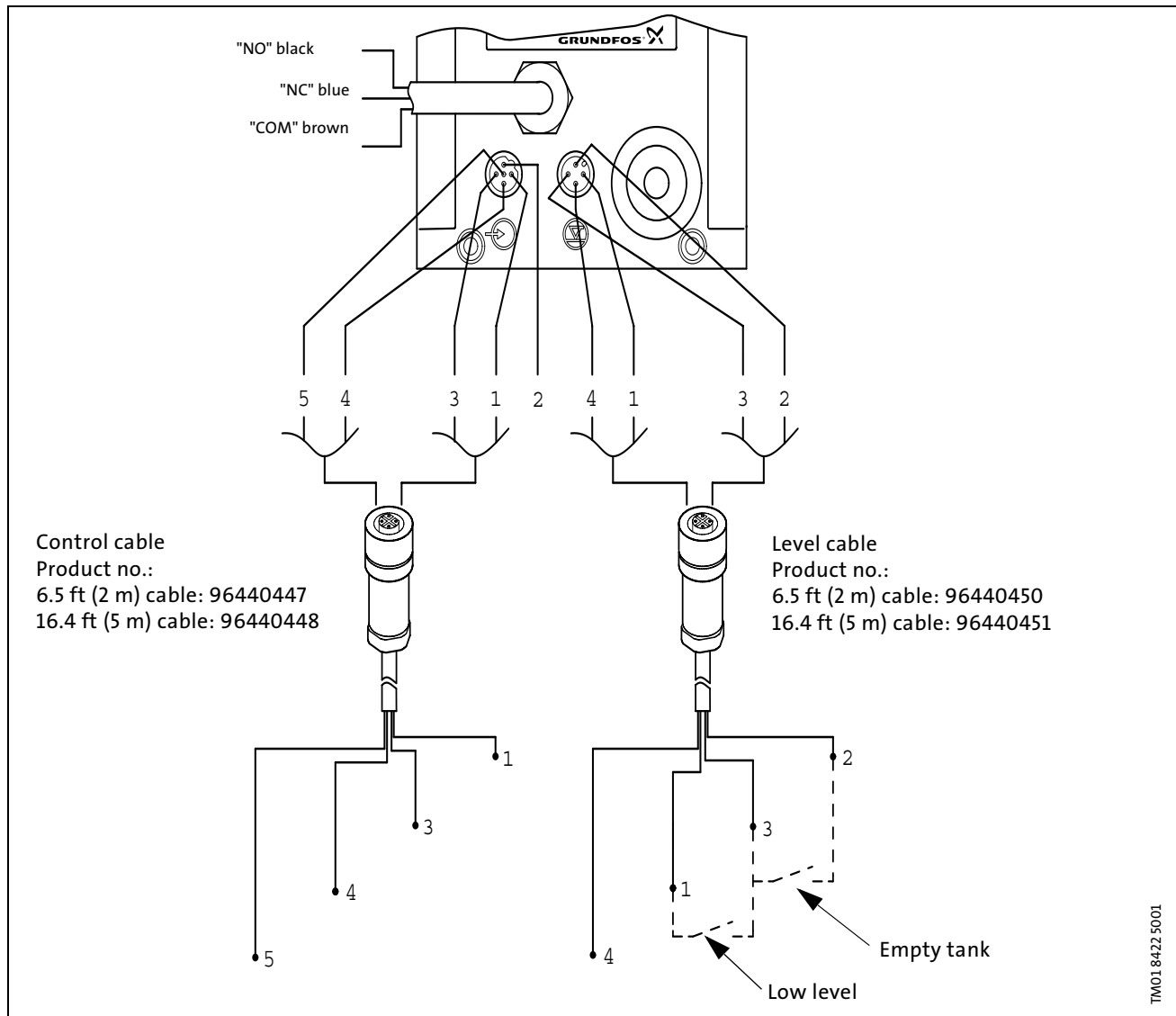

Control input

Number	1	2	3	4	5
Color	Brown	White	Blue	Black	Grey
Function	(-) Pulse input ^{★1}	Not used	(+) Pulse input ^{★1}	(-) 4-20 mA input ^{★2}	(+) 4 - 20 mA input ^{★2}

Level input

Number	1	2	3	4
Color	Brown	White	Blue	Black
Function	(-) Low level ^{★3}	(-) Empty tank/pump stop	(+) Low level/empty tank ^{★3}	0 (not used)

^{★1} In analog, timer, and manual mode the pulse input works as stop input (closed contact = stop).

^{★2} In pulse and batch mode, the analog input functions as stop input (closed contact = stop).

^{★3} This input can be changed to dosing monitoring input. Check page 54 for dosing monitor.

Note: Level and stop inputs can be changed from NO (normally open) to NC (normally closed) function, see page 22.

Dimensions, DME and DMSI

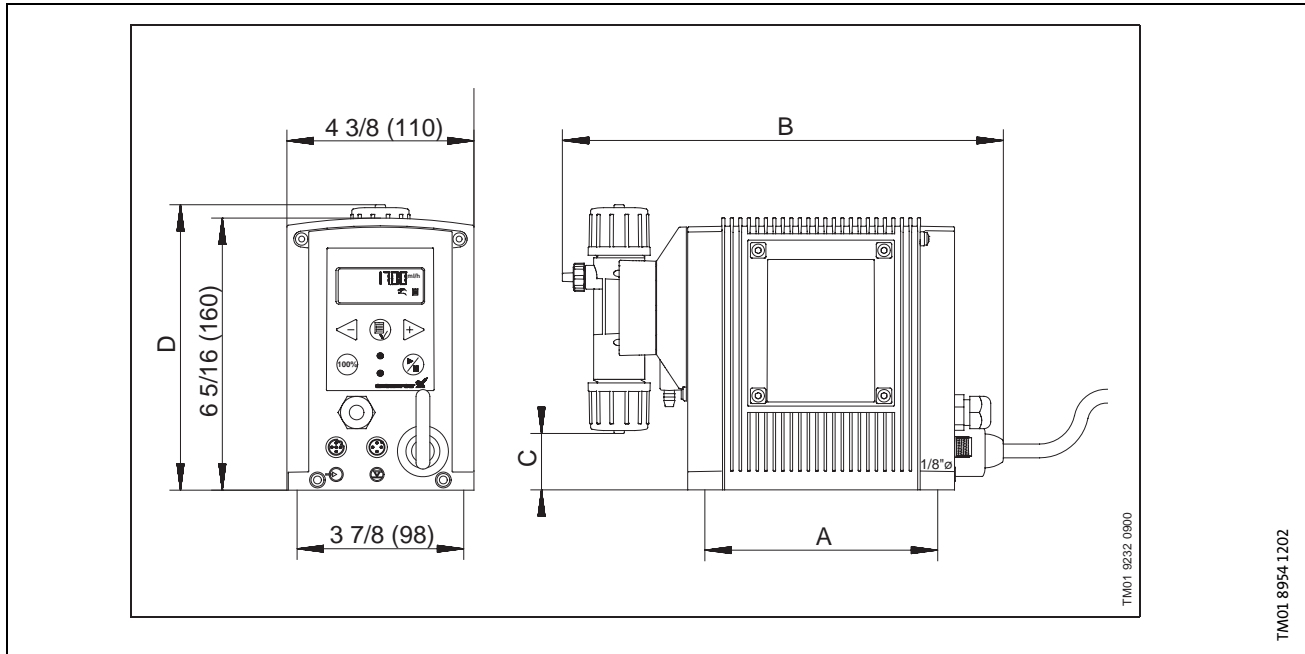

Pump type	DME 2 DMS 2	DMS 4	DME 8 DMS 8	DME 12 DMS 12	DME 19	DME 48
A [in (mm)]	5.4 (137)			7.56 (192)		
B [in (mm)]	9.4 (239)			11.57 (294)		
C [in (mm)]	1.4 (36)			.59 (15)		
D [in (mm)]	6.6 (168)			7.40 (188)		

Overview of functions

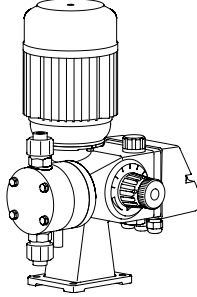
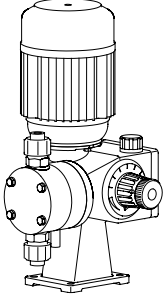
	DMM-AR	DMM-B
	 <small>TM01.8965.0900</small>	 <small>TM01.8966.0900</small>
Capacity control		
Internal stroke frequency control	•	
Internal stroke speed control		
Stroke length setting	•	•
Control panel		
Capacity setting in liters, milliliters, or U.S. gallons		
Display with soft-touch buttons	•	
Easy setup menu with language options		
On/off button	•	
Priming button (temporary maximum speed)		
Green indicator light for operating indication	•	
Red indicator light for fault indication	•	
Lock function for control panel		
Side-fitted option		
Operating modes		
Manual control	•	•
Pulse control	•	
Analog 0/4-20 mA control	•	
Timer-based batch control		
Pulse-based batch control		
Functions		
Dosing monitoring		
Dual-level control	•	
Calibration of pump to actual installation		
Anti-cavitation (reduced suction speed)		
Capacity limitation		
Counters for strokes, operating hours and power on/off		
Fieldbus communication (variants AP and AG)		
Maximum permissible stroke frequency adjustment	•	
Power Supply		
Switch-mode power supply		
Inputs/outputs		
Input for pulse control		
Input for analog 0/4-20 mA control (0/4-20 mA for DMM)	•	
Input for dual-level control	•	
External start/stop input	•	
Alarm relay output (variant AR)	•	
Input for external on/off switch	•	

Capacity control

Functional description, DMM-AR

The capacity of the DMM-AR is set by setting the stroke length on the gearbox knob and/or setting the stroke frequency on the control panel. The controller controls the stroke frequency by starting and stopping the motor according to the set stroke frequency. The figure below shows two examples:

1. The pump is running at 100% capacity, i.e. at maximum stroke length and stroke frequency.
2. The pump is running at 25% capacity, i.e. at 50% stroke length and 50% stroke frequency.

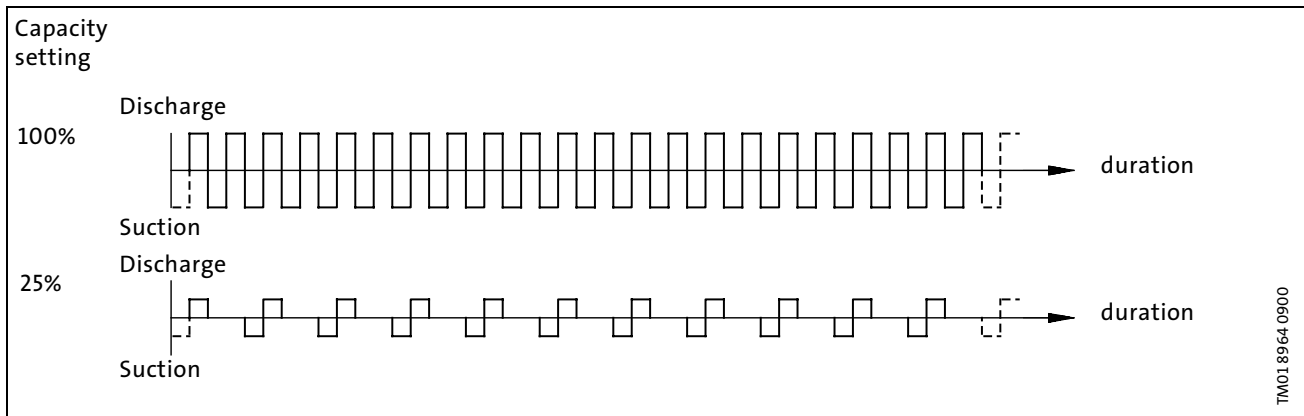

DMM, variant B

On the DMM-B, the capacity is set by setting the stroke length on the gearbox knob. As shown in the figure below, the stroke frequency is constant—only the stroke length is adjusted.

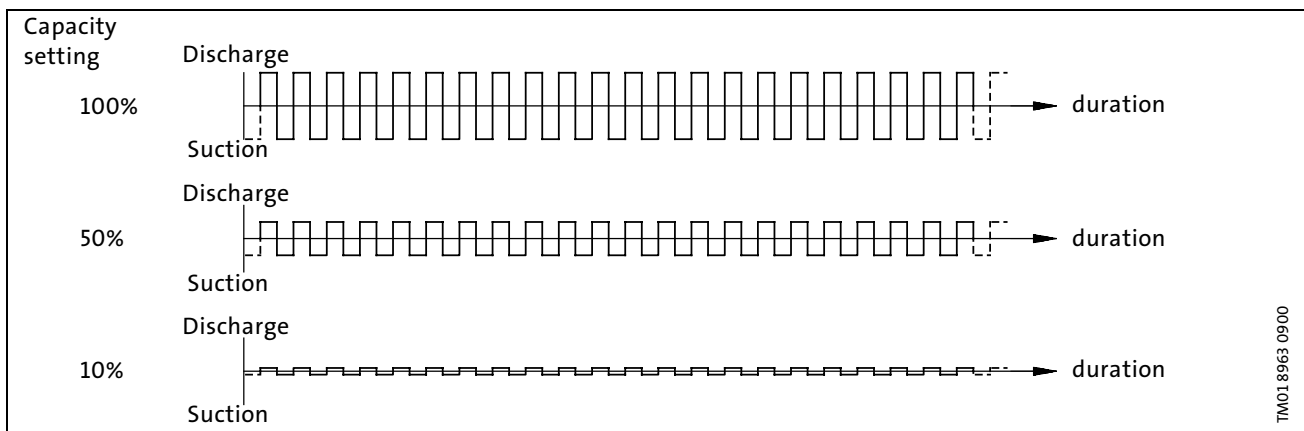

Settings and operations, DMM

Stroke length setting

Note: the pump must be operating when the stroke length is set. Set the stroke length in the following way:

1. Loosen the locking screw in the middle of the gear-box knob (counterclockwise).
2. Set the stroke length to the desired value, according to the performance table on the pump or the performance curves on pages 41-43.
3. Retighten the locking screw while the stroke length setting is maintained.

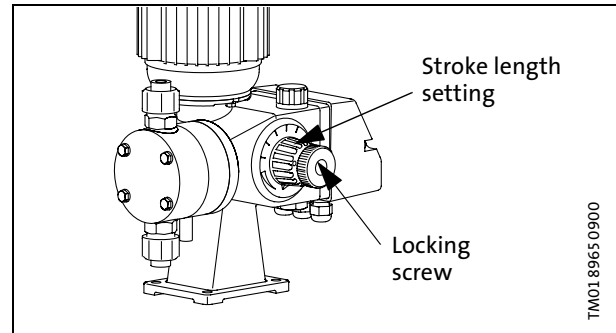

Control panel DMM-AR

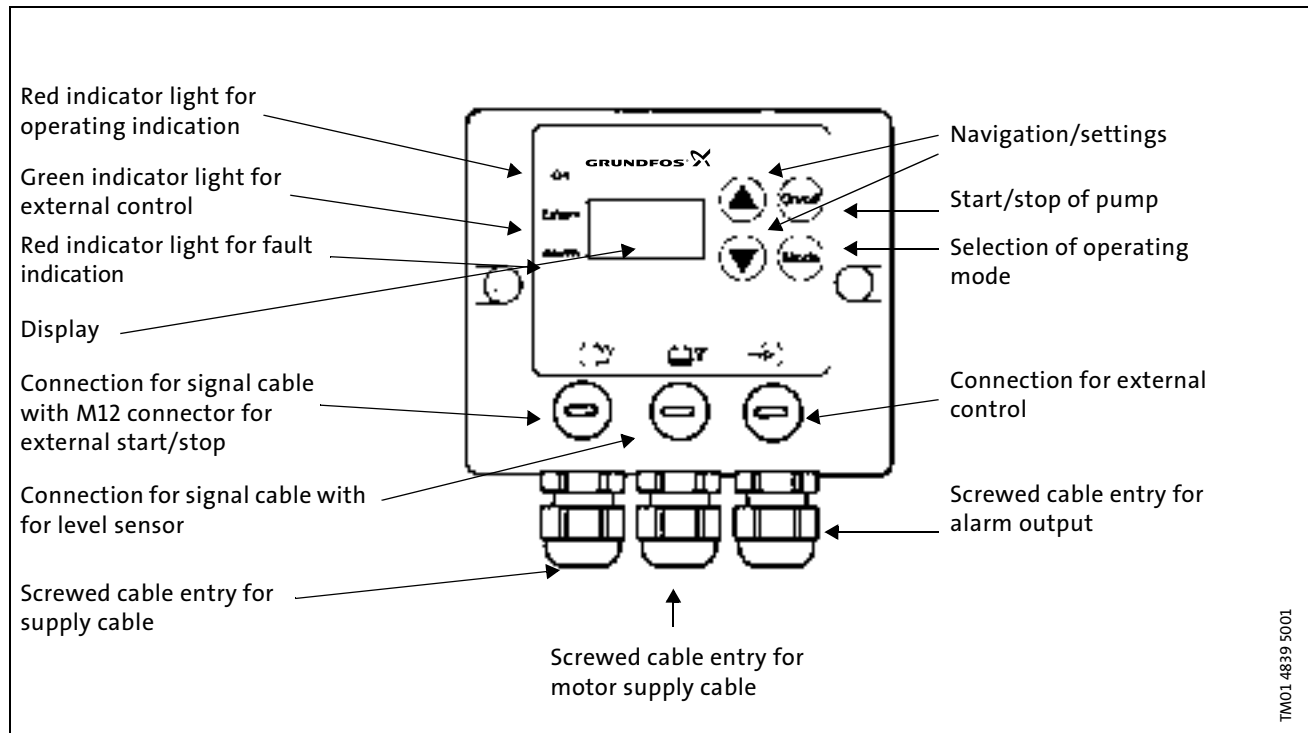

Start/stop

Depress the **On/off** button to start the pump. When the pump is stopped, **OFF** will appear in the display.

If the pump is stopped via an external start/stop signal, the indicator light **Extern** will be on.

Maximum permissible stroke frequency

To set the maximum permissible stroke frequency, proceed as follows:

1. Press the buttons **Mode** and **On/off** simultaneously and switch on the electricity to the pump. The display shows the maximum permissible stroke frequency.
2. Keep the buttons pressed and change the value by means of the buttons **▲** and **▼**.
3. Stop pressing the buttons **Mode** and **On/off**. The pump restarts automatically when the buttons are no longer pressed.

Alarm output

As an alarm output, the pump has an internal potential-free contact.

Change of factory setting:

To change the alarm output function, press the buttons **Mode** and ▼ simultaneously and switch on the electricity supply to the pump. **RE1** appears in the display.

Return to factory setting:

To change the alarm output function back to the factory setting, press the buttons **Mode** and ▲ simultaneously and switch on the electricity supply to the pump. **RE0** appears in the display.

The following table shows the operating conditions under which the alarm output is activated when the pump is running under **factory setting**.

Condition	Green indicator light	Red indicator light	Alarm output
Pump running	On	Off	
Set to stop	Flashing	Off	
Pump fault	Off	On	
Supply failure	Off	Off	
Pump running, low chemical level★	On	On	
Empty tank★	Off	On	
Analog signal < 3 mA	Off	On	

★ Requires connection to level sensors.

Operating modes

Possible operating modes:

- manual control
- pulse control
- analog control

To select the operating mode, press the buttons **Mode** and ▼ or ▲ simultaneously.

Button	Display	Description
Mode +		
	▼ INT	manual control
	▼ 1.64	pulse control
	▼ 1.32	pulse control
	▼ 1.16	pulse control
	▼ 1.8	pulse control
	▼ 1.4	pulse control
	▼ 1.2	pulse control
	▼ 64.1	pulse control
	▼ 32.1	pulse control
	▼ 16.1	pulse control
	▼ 8.1	pulse control
	▼ 4.1	pulse control
	▼ 2.1	pulse control
	▼ 1.1	pulse control
	▼ 4.20	analog control
▼ 0.20	analog control	

Manual control

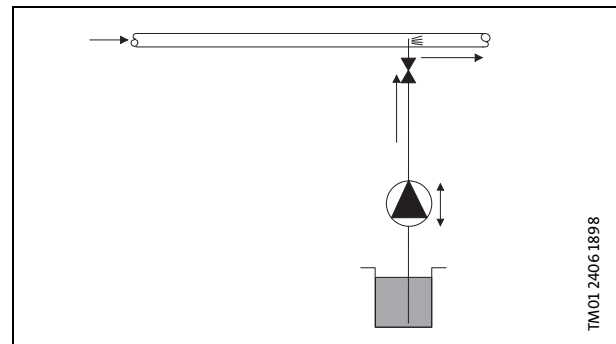

In the case of manual control, select a stroke length and a stroke frequency. Consequently, the pump will dose a constant quantity of chemical per time unit, irrespective of the process.

To select the operating mode, proceed as follows:

1. Press the buttons **Mode** and ▼ or ▲ simultaneously until **INT** appears in the display.
2. Stop pressing the button **Mode**. The display shows the actual stroke frequency in strokes/min.
3. Change the stroke frequency by means of the buttons ▼ and ▲.

Pulse and analog control

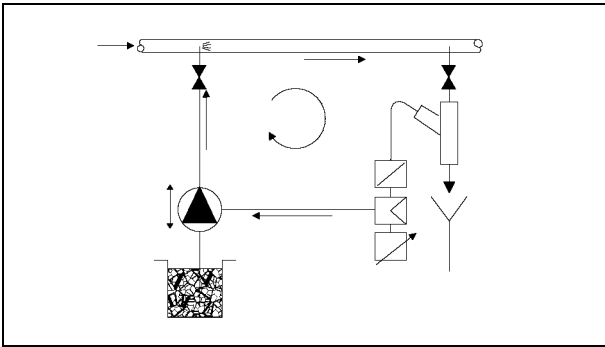
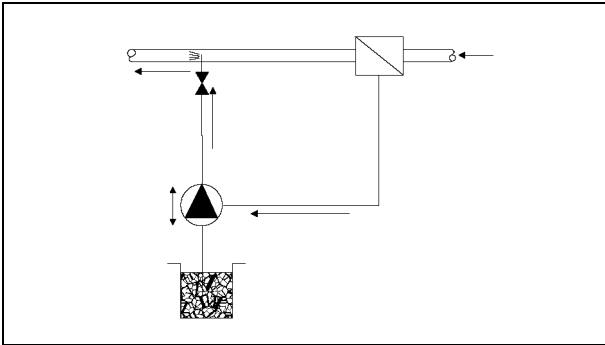

Control can be selected with:

- pulse signal
- analog signal.

Pulse control

In the case of pulse control, select a stroke length and pulse multiplication/pulse division, if desired. Consequently, the pump will dose a constant quantity of chemical per pulse.

For stroke length setting, see page 35.

To set the pulse multiplication/pulse division, press the buttons **Mode** and ▼ or ▲ simultaneously until the display shows the following:

- **1.1** for a ratio of 1.1, i.e. 1 pump stroke to 1 pulse,
- **1.2** to **1.64** for pulse multiplication or,
- **2.1** to **64.1** for pulse division.

The indicator light **Extern** is on.

Example:

1.64 means that the pump needs 1 pulse to generate 64 pump strokes.

64.1 means that the pump needs 64 pulses to generate 1 pump stroke.

The following settings are possible: 1, 2, 4, 8, 16, 32 and 64.

Analog control

In the case of analog control, select a stroke length and an input signal. The pump will dose a quantity of chemical which is proportional to the input signal.

For stroke length signal, see page 35.

If the pump is not receiving or recognizing an analog signal, the display will read **E-1**.

To set the operating mode, press the buttons **Mode** and ▼ or ▲ simultaneously until the following appears in the display:

The indicator light **Extern** is on.

The stroke frequency of the pump will be proportional to the input signal, according to the curve shown below.

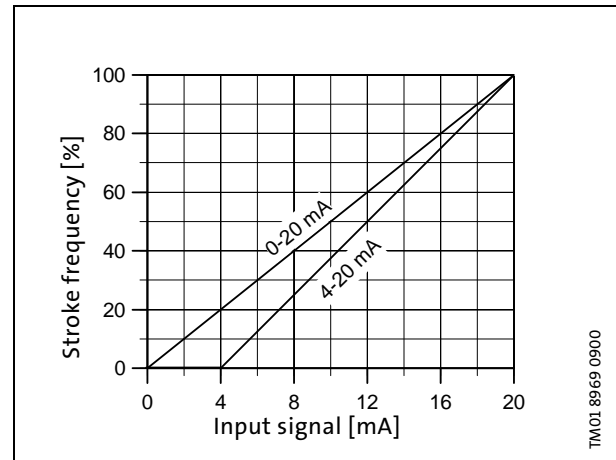

Level control

DMM-AR only

The pump can be fitted with a level control unit to monitor the chemical level in the tank.

The pump can react to two level signals. The following table shows the pump reactions to the sensor signals.

Level sensors	Pump reaction
Upper sensor activated	<ul style="list-style-type: none"> • Red indicator light is on. • Pump running. • Alarm relay activated.
Lower sensor activated	<ul style="list-style-type: none"> • Red indicator light is on. • Pump stopped. • Alarm relay activated.

Maximum permissible stroke frequency

DMM-AR only

The maximum stroke frequency of the pump can be limited, for instance to adapt the pump operation to an analog 0/4-20 mA signal without reducing the stroke length.

Wiring diagram

See page 49 for input/output data.

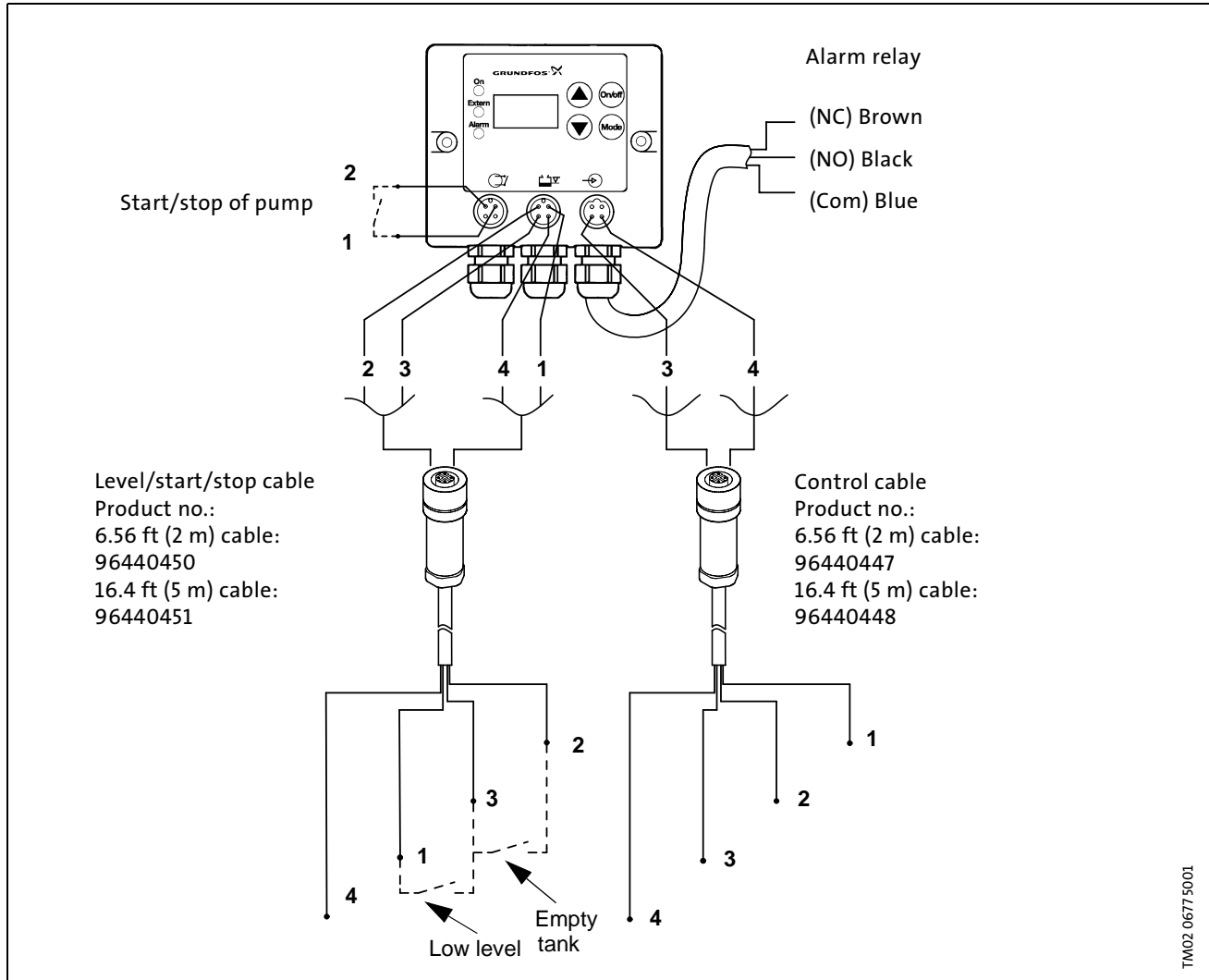

Control input

Number	1	2	3	4
Color	Brown	White	Blue	Black
Function	Not used	Not used	(+) Pulse input, (+) 4-20 mA input	(-) Pulse input, (-) 4-20 mA input

Level input

Number	1	2	3	4
Color	Brown	White	Blue	Black
Function	(-) Low level	(-) Empty tank/pump stop	(+) Low level/empty tank	(↓) Earth (optional)

Motor start-stop (closed contact = stopped motor)

Number	1	2	3	4
Color	Brown	White	Blue	Black
Function	Start/stop of pump		Not used	Not used

Sectional drawing, DMM

DMM 4 to DMM 155

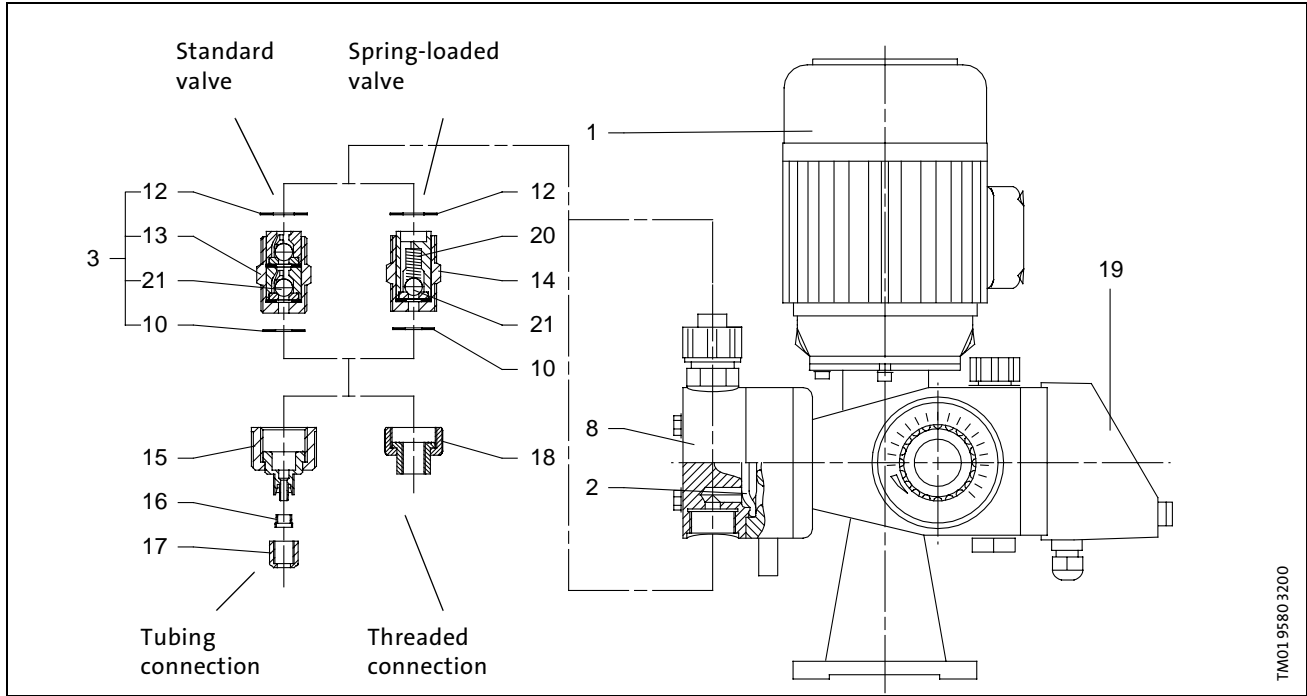

DMM 160 to DMM 390

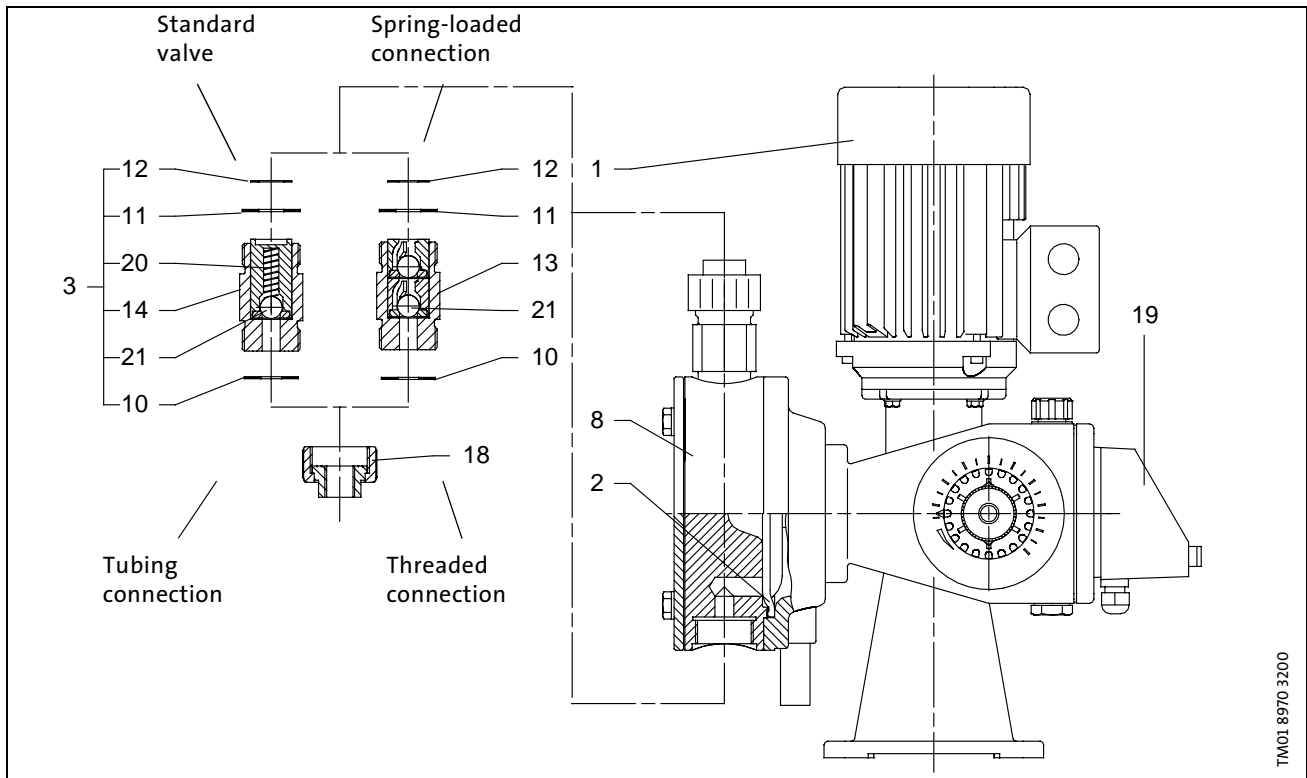

Sectional drawing, DMM

DMM 440 to DMM 990

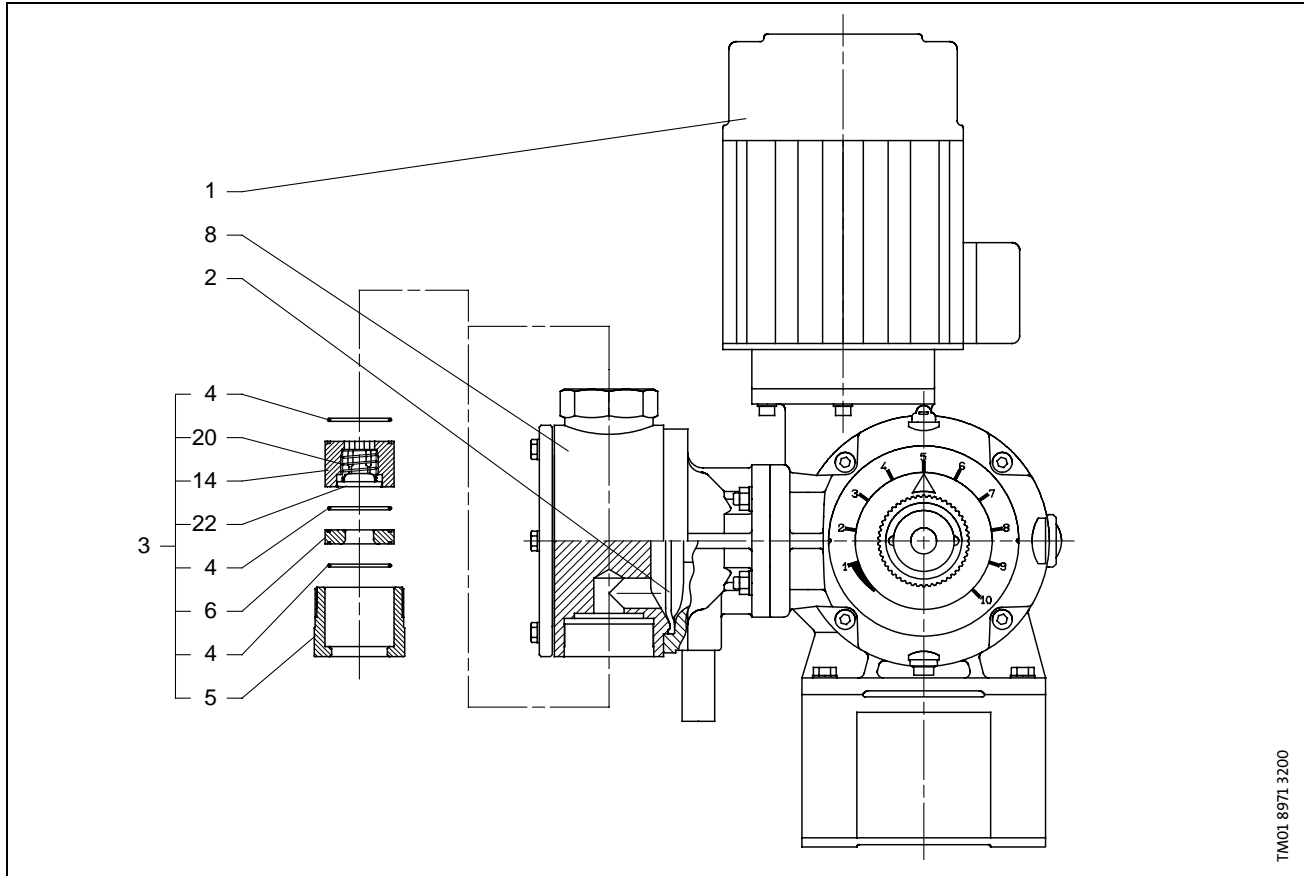

Construction

The Grundfos DMM pumps are mechanical diaphragm dosing pumps. The pumps are driven by an external fan-cooled motor, connected to a single-stage worm reduction gear. The strokes are generated by an eccentric which moves the diaphragm by means of a spring-loaded plunger. The injection stroke is activated by the eccentric and the suction stroke by the spring return.

The pumps are designed for capacities between 1.06 and 261.5 gph (4 and 990 l/h) and a maximum pressure of 145 psi (10 bar). The pumps are fitted with a separation chamber which, in the event of a diaphragm failure, prevents the pumped liquid from flooding the pump unit or other system components.

Material specification

Pos.	Description	Material options
1	Motor	-
2	Diaphragm	Textile-reinforced EPDM, PTFE-coated
3	Valve assembly	-
4	O-ring	EPDM/FKM
5	Valve casing	PP/316 Stainless Steel
6	Valve seat	PP/316 Stainless Steel
8	Dosing head	PP/316 Stainless Steel
10	Valve gasket	CSM/FKM/Centellen C*1/PTFE
11	Valve gasket	CSM/FKM/Centellen C*1/PTFE
12	Valve gasket	CSM/FKM/Centellen C*1/PTFE
13	Valve, double ball	-
14	Valve, spring-loaded	-
15	Union nut	PP/316 Stainless Steel
16	Clamping ring	PP
17	Union nut, tubing	PP
18	Union nut, threaded connection	PP/316 Stainless Steel
19	Control unit (DMM-AR only)	GKAlSi12/PPO
20	Spring	Hastelloy
21	Ball	Ceramic/glass/PTFE/316 Stainless Steel
22	Valve disk	PVDF/316 Stainless Steel

★1 Centellen C is a Hecker trademark.

DMM-AR, B

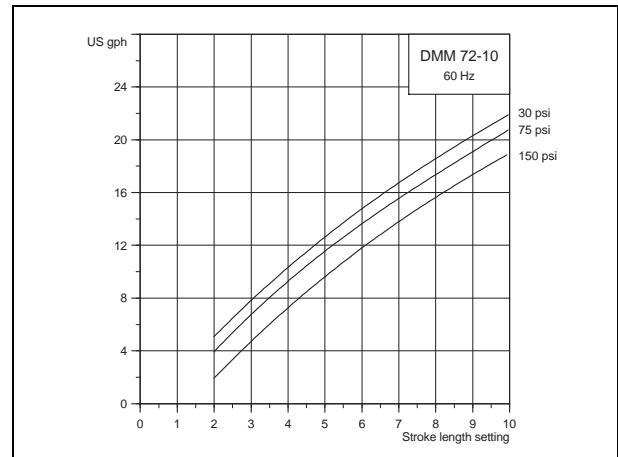
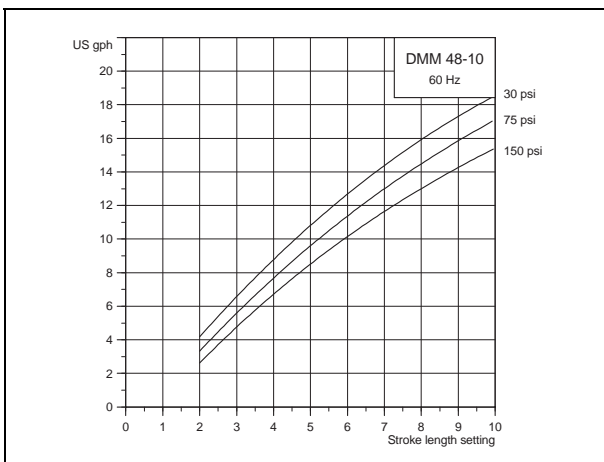
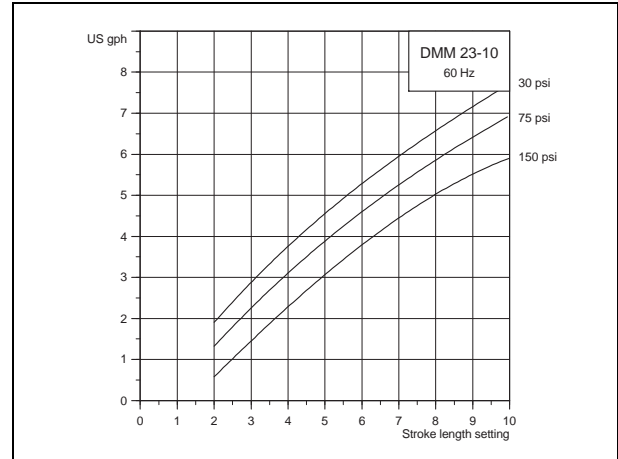
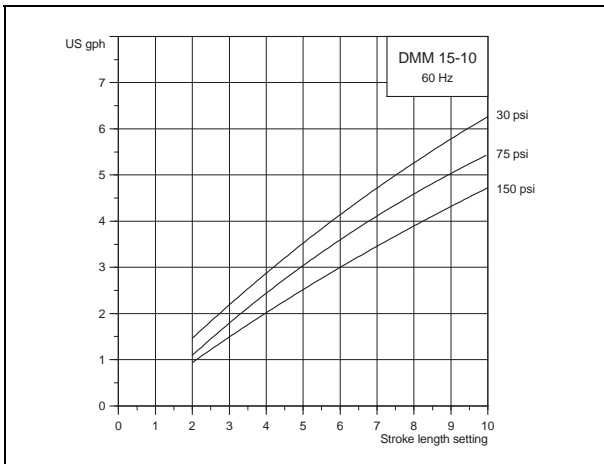
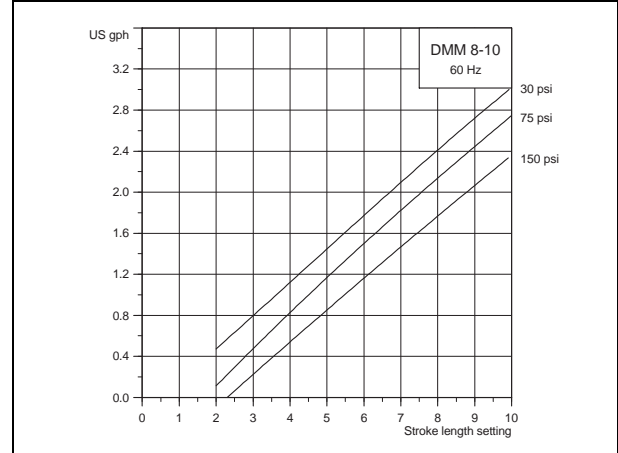
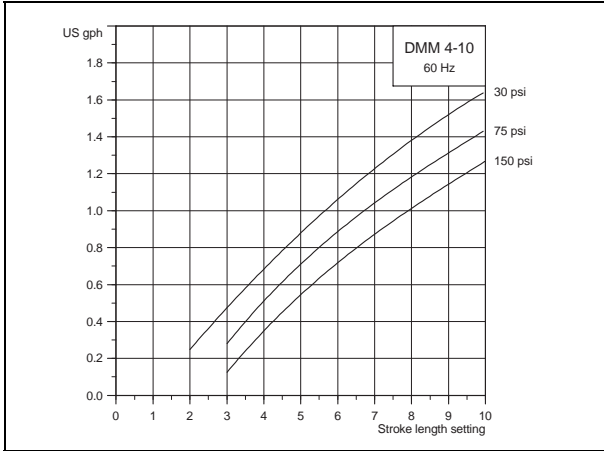

DMM-AR, B

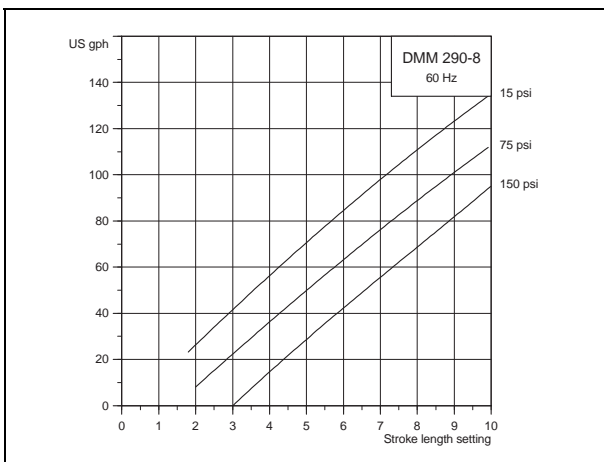
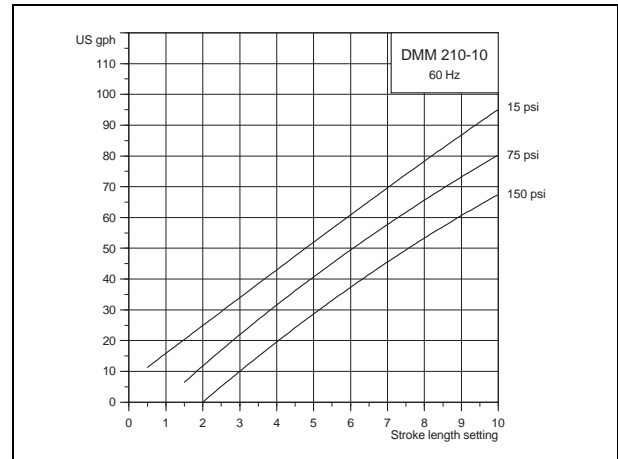
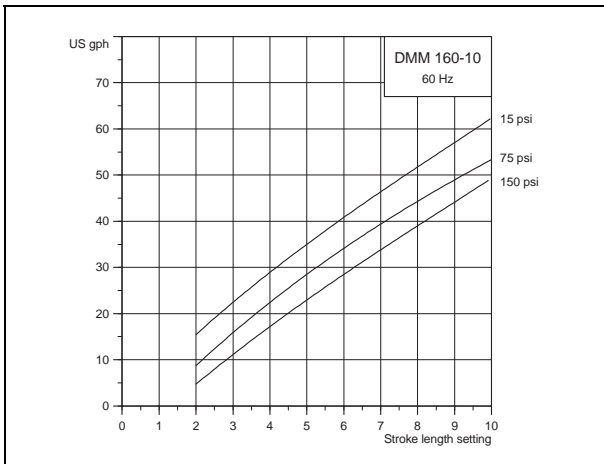
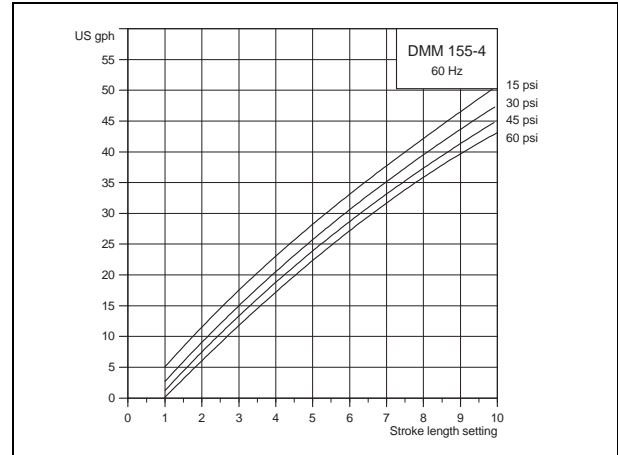
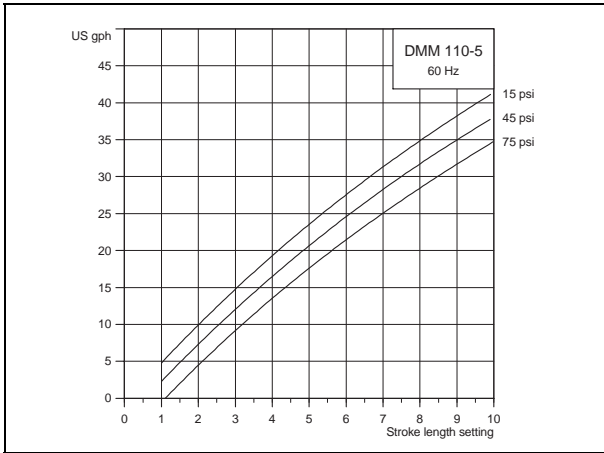

DMM-B only

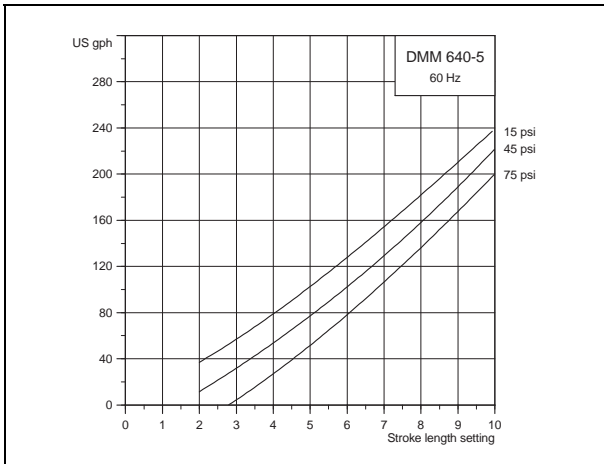
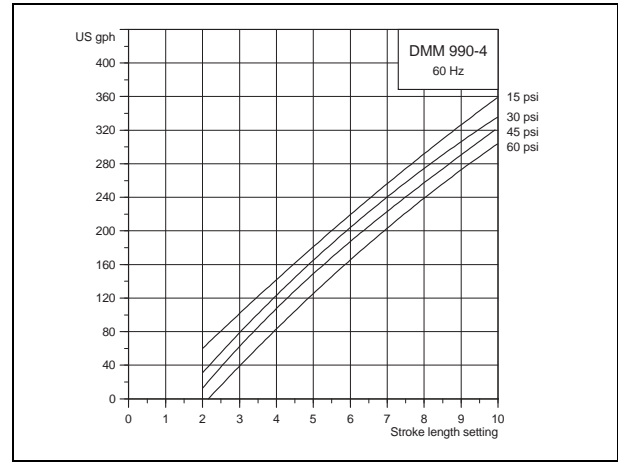
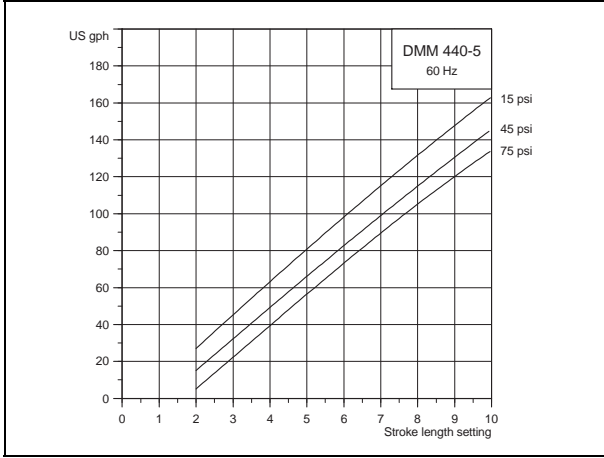

DMM, 60 Hz

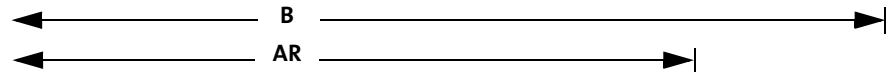

DMM		4	8	15	23	48	72	110	155	160	210	290	440	640	990
Mechanical data															
Maximum capacity at maximum pressure	[gph]	1.3	2.4	4.8	6.1	15.3	19.0	33.8	42.3	49.4	66.0	92.5	139.5	202.9	313.8
	[l/h]	4.8	9	18	23	58	72	128	160	187	250	350	528	768	1188
	[ml/stroke]	2.6	2.6	2.6	2.6	8.5	8.5	19	19	36.5	36.5	51.2	165	165	165
Maximum pressure	[psi]	145	145	145	145	145	145	72	58	145	145	116	72	72	58
	[bar]	10	10	10	10	10	10	5	4	10	10	8	5	5	4
Diaphragm diameter	[in]	2	2	2	2	2.5	2.5	3.5	3.5	4.7	4.7	5.9	7.3	7.3	7.3
	[mm]	52	52	52	52	64	64	90	90	120	120	150	185	185	185
Maximum stroke frequency	[stroke/min.]	26	48	95	142	95	142	95	142	71	95	95	47	70	101
Maximum suction lift during operation	[ft]	16.4	16.4	12.5	8.2	13.1	10.8	8.2	6.5	9.8	8.2	8.2	9.8	9.8	9.8
	[m]	5	5	3.8	2.5	4	3.3	2.5	2	3	2.5	2.5	3	3	3
Maximum viscosity with spring-loaded valves ★ ²	[cp]	3000★ ¹			1000					3000	1000	3000	1000		
Maximum viscosity without spring-loaded valves	[cp]	400													
Maximum ambient temperature	[°F]	104													
	[°C]	40													
Maximum liquid temperature	[°F]	122													
	[°C]	50													
Accuracy of repeatability		±2%													
Weight (plastic pump head)	[lb]	18.1	18.1	18.1	18.1	18.5	18.1	22	22	37.5	37.5	39.7	83.8	83.8	83.8
	[kg]	8.2	8.2	8.2	8.2	8.4	8.2	10	10	17	17	18	38	38	38
Weight (stainless steel pump head)	[lb]	24.2	24.2	24.2	24.2	26.5	26.5	44.1	44.1	48.4	48.4	57.3	105.9	105.9	105.9
	[kg]	11	11	11	11	12	12	20	20	22	22	26	48	48	48
Input/output data (DMM-AR only)															
Voltage to level sensor input	[VDC]	5													
Maximum loop resistance in level signal circuit	[ohm]	350													
Voltage to pulse input	[VDC]	5													
Maximum loop resistance in pulse circuit	[ohm]	350													
Impedance in 0/4-20 mA input	[ohm]	250													
Maximum voltage, alarm relay output	[V]	250													
Maximum load of alarm relay output	[A]	2													
Standard motor data (DMM-AR, DMM-B only) 120 V															
Phase		1													
Frequency	[Hz]	60													
Enclosure class		IP55													
Insulation class		F													
Standard motor data (DMM-B only) 230/460 V															
Phase		-													
Frequency	[Hz]	60													
Enclosure class		IP55													
Insulation class		F													
Standard motor data (DMM-B only) 575 V															
Phase		-													
Frequency	[Hz]	60													
Enclosure class		IP55													
Insulation class		F													

★¹ At any counter-pressure if the pump is calibrated to the actual installation.

★² The maximum stroke frequency varies according to calibration.

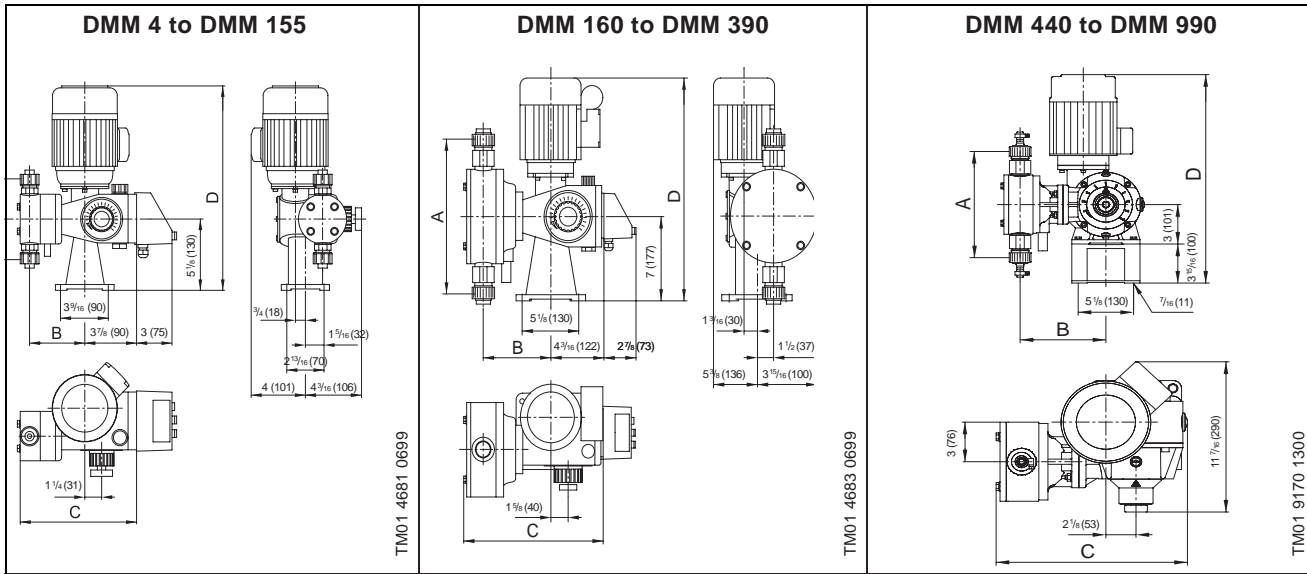

Pump type	Dimensions [in (mm)]			
	A	B	C	D
DMM 4	4.25 (108)	3.74 (95)	8.35 (212)	4.65 (372)
DMM 8	4.25 (108)	3.74 (95)	8.35 (212)	4.65 (372)
DMM 15	4.25 (108)	3.74 (95)	8.35 (212)	4.65 (372)
DMM 23	4.25 (108)	3.74 (95)	8.35 (212)	4.65 (372)
DMM 48	5.79 (147)	4.06 (103)	8.82 (224)	4.65 (372)
DMM 72	5.79 (147)	4.06 (103)	8.82 (224)	4.65 (372)
DMM 110	9.57 (243)	4.61 (117)	10.20 (259)	4.65 (372)
DMM 155	9.57 (243)	4.61 (117)	10.20 (259)	4.65 (372)
DMM 160	10.95 (278)	5.83 (148)	12.48 (317)	19.13 (486)
DMM 210	10.95 (278)	5.83 (148)	12.48 (317)	19.13 (486)
DMM 260	10.95 (278)	5.83 (148)	12.48 (317)	19.13 (486)
DMM 290	12.52 (318)	6.02 (153)	12.60 (320)	19.13 (486)
DMM 390	12.52 (318)	6.02 (153)	12.60(320)	19.13 (486)
DMM 440	10.43 (265)	8.86 (225)	16.73 (425)	20.87 (530)
DMM 640	10.43 (265)	8.86 (225)	16.73 (425)	20.87 (530)
DMM 990	10.43 (265)	8.86 (225)	16.73 (425)	20.87 (530)

Overview

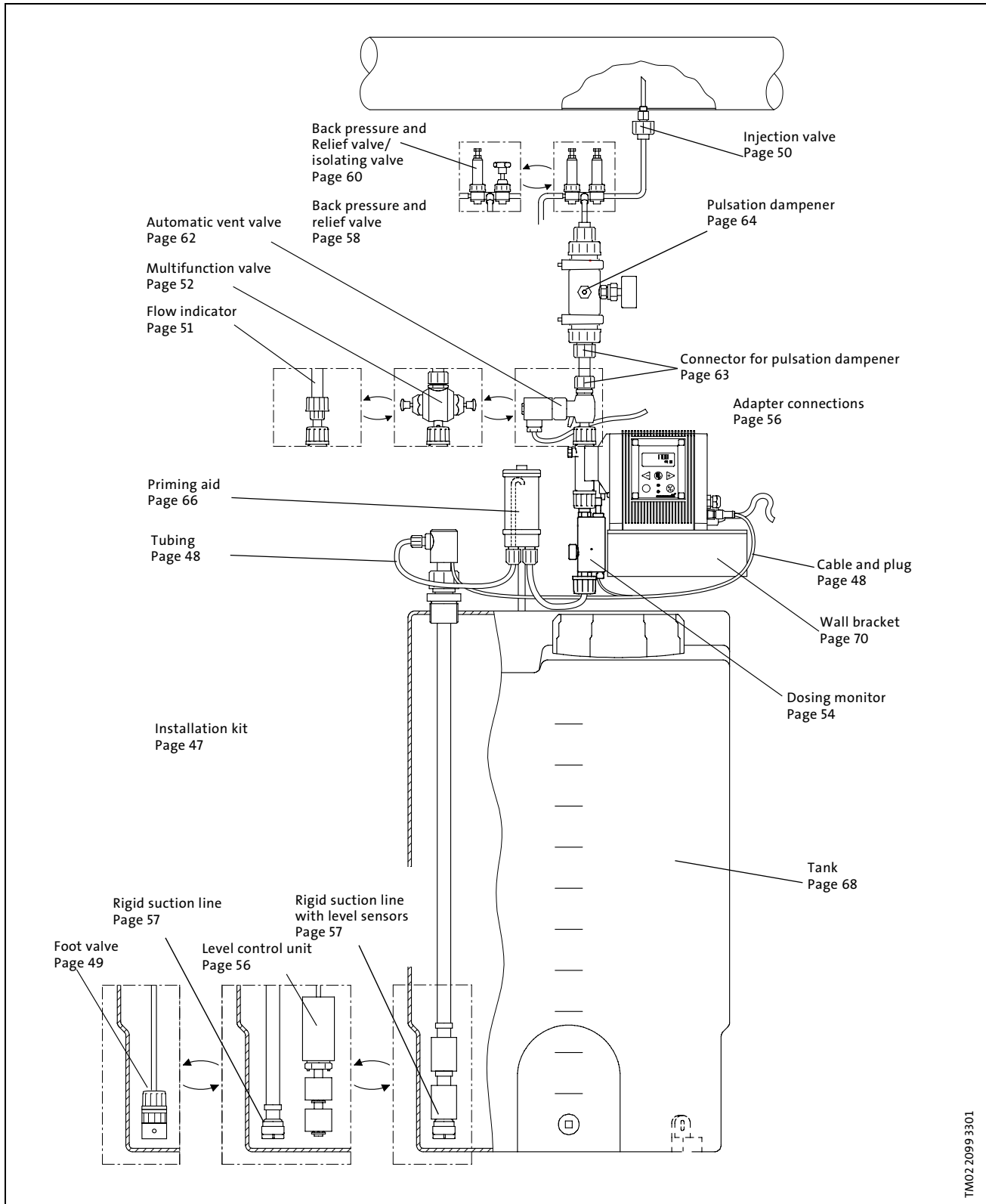

Installation kit

The installation kit includes:

- foot non-return valve with strainer and weight
- injection non-return valve, spring-loaded
- 20 ft (6 m) PE discharge tubing
- 6 ft (2 m) PVC suction tubing
- 6 ft (2 m) PVC vent tubing.



TM01 8956 0500

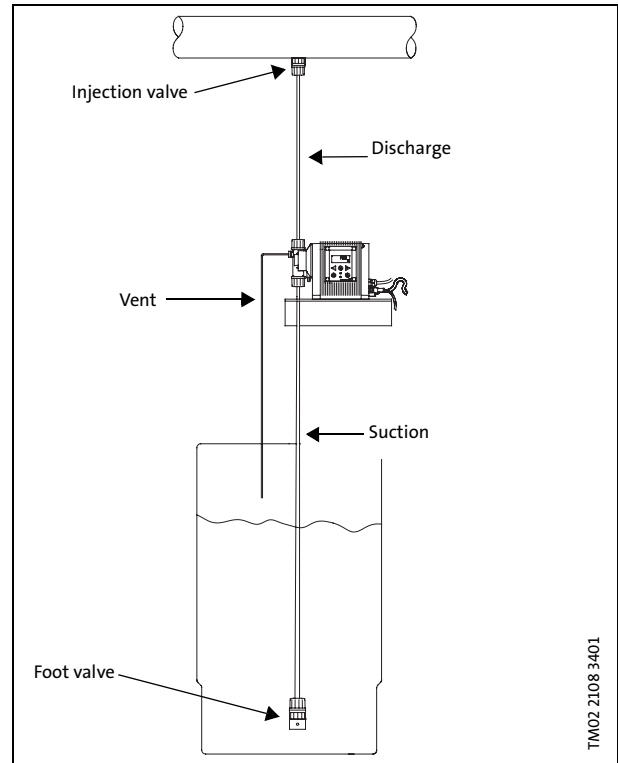

TM02 2108 3401

For pump types	Materials			Inner/outer tubing diameters		Material number
	Pump head	Gaskets	Valve ball	Suc./dis. tubing [in]	Vent tubing [in]	
DMS, DME2 to 12	PP	EPDM	Ceramics	0.25 x 0.375	0.17 x 0.25	96479881
DMS, DME2 to 12	PP	FKM	Ceramics	0.25 x 0.375	0.17 x 0.25	96479898
DMS, DME2 to 12	PVDF	FKM	Ceramics	0.25 x 0.375	0.17 x 0.25	96479899
DME19 to 48	PP	EPDM	Ceramics	0.375 x 0.5	0.17 x 0.25	96479947
DME19 to 48	PP	FKM	Ceramics	0.375 x 0.5	0.17 x 0.25	96479948
DME19 to 48	PVDF	FKM	Ceramics	0.375 x 0.5	0.17 x 0.25	96479949

Cable and plug kit

Cable and plug connect the pump to external control devices, such as process controllers, flow meters, start/stop contacts, and level sensors.

Grundfos level control units are factory-fitted with a cable and plug connection for Grundfos dosing pumps.

The cables and plugs fit all dosing pumps, DME, DMS-A and DMM-AR.

Cable material: PUR.

Plug type: M12.



TM01 8955 0900

Type	Signal	Material	Cable Length [ft.]	Plug type	Number of Poles	Material number
Cable molded with plug	Pulse, 4-20 mA, start/stop	PUR	6.5	M12	4	96440447
Cable molded with plug	Pulse, 4-20 mA, start/stop	PUR	16	M12	4	96440448
Plug with terminals without cable	Pulse, 4-20 mA, start/stop	PUR	-	M12	4	96440449

Tubing

Tubing in various materials, sizes and lengths.

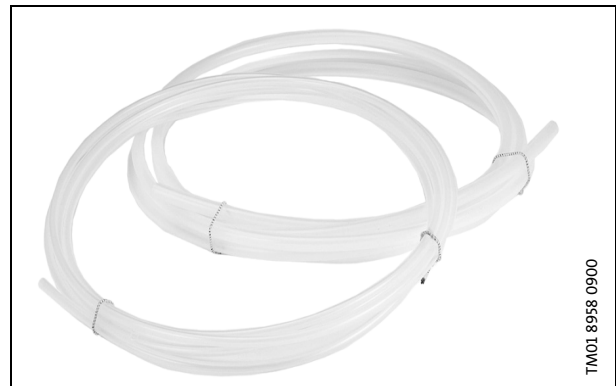

TM01 8958 0900

Model	Inner/Outer Diameter [in]	Length [ft]	Material	Maximum Pressure [psi]	Material Number
0.17 x 0.25", 20 ft, PVC	0.17 x 0.25	20	PVC	85	91127749
0.25 x 0.375", 100 ft, PVC	0.25 x 0.375	100	PVC	73	91127750
0.25 x 0.375", 20 ft, PE	0.25 x 0.375	20	PE	192	91127825
0.25 x 0.375", 100 ft, PE	0.25 x 0.375	100	PE	192	91127751
0.375 x 0.5", 20 ft, PE	0.375 x 0.5	20	PE	123	91127826
Tubing 0.375 x 0.5", 100 ft, PE	0.375 x 0.5	100	PE	123	91127752
Tubing 0.25 x 0.375", 100 ft, ETFE	0.25 x 0.375	100	ETFE	290	91127753

Foot valve kit

Foot valve complete with non-return valve, strainer and hose or pipe connection.



Dimensions

DN 4, DN 8	DN 6, DN 10, DN 15, DN 25	
	Hose clamp	Pipe cementing
<p style="text-align: right;">TM01 9276 1600</p>	<p style="text-align: right;">TM01 2201 1600</p>	<p style="text-align: right;">TM01 9277 1600</p>

Model	Inner/Outer Tubing Diameter [in]	Pump Head Material	Gaskets Material	Valve Ball Material	Maximum Flow [gph]	Connection Type	Material Number
DN4 PP/EPDM 0.25 x 0.375"	0.25 x 0.375	PP	EPDM	Ceramics	4.0	Tubing	96479782
DN4 PP/FKM 0.25 x 0.375"	0.25 x 0.375	PP	FKM	Ceramics	4.0	Tubing	96479784
DN4 PVDF/FKM 0.25 x 0.375"	0.25 x 0.375	PVDF	FKM	Ceramics	4.0	Tubing	96479787
DN6 SS 0.25" NPT"	NPT 0.25	SS	CSM	SS	12.7	Threaded	96479794
DN8 PP/EPDM 0.375 x 0.5"	0.375 x 0.5	PP	EPDM	Ceramics	19.0	Tubing	96479798
DN8 PVDF/FKM 0.375 x 0.5"	0.375 x 0.5	PVDF	FKM	Ceramics	19.0	Tubing	96479801

Injection valve kit

Injection valve complete with non-return valve, injection pipe and tubing or pipe connection.

Spring material: Hastelloy
 Opening pressure: DN 4, DN 8: 0.7 bar
 DN 6, 1.1 bar
 Max. temperature: PP, PVDF: 122°F (50°C)
 PVC: 104°F (40°C)
 Stainless steel: 176°F (80°C)

Dimensions

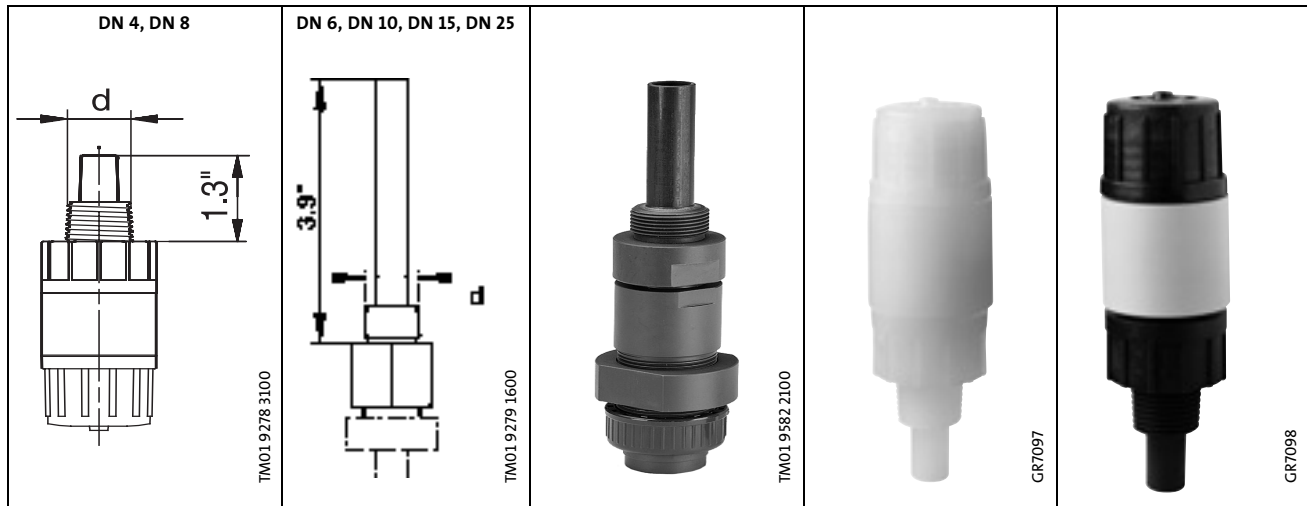

Model	Inner/Outer Tubing Diameter [in]	Pump Head Material	Gaskets Material	Valve Ball Material	Maximum Flow [gph]	Pipe Fitting Size [d]	Material Number
DN4 PP/EPDM 0.25 x 0.375	0.25 x 0.375	PP	EPDM	Ceramics	4.0	NPT 1/2"	96479805
DN4 PP/FKM 0.25 x 0.375	0.25 x 0.375	PP	FKM	Ceramics	4.0	NPT 1/2"	96479806
DN4 PVDF/FKM 0.25 x 0.375	0.25 x 0.375	PVDF	FKM	Ceramics	4.0	NPT 1/2"	96479807
DN6 SS 0.25" NPT	NPT 0.25	SS	CSM	SS	19.0	NPT 1/2"	96479804
DN8 PP/FKM 0.375 x 0.5	0.375 x 0.5	PP	FKM	Ceramics	19.0	NPT 1/2"	96479808
DN8 PVDF/FKM 0.375 x 0.5	0.375 x 0.5	PVDF	FKM	Ceramics	19.0	NPT 1/2"	96479809

Flow indicator

The flow indicator is used for discharge monitoring.

When the dosing pump is discharging liquid, the white ball will jump in the transparent pipe. Each dosing stroke causes a ball jump. The flow indicator is designed so that ball movements can be seen at flow rates from .026 to 11.88 gph (0.1 to 45 l/h).

At a steady flow, the ball will always be in the top position.

The flow indicator installs and retrofits easily.

Technical data

Material: PVC grey, PVC transparent, PVDF, FKM, ceramics Al₂O₃.

Maximum pressure: 145 psi (10 bar).

Maximum pulsed flow: 11.88 gph (45 l/h).

Dimensions

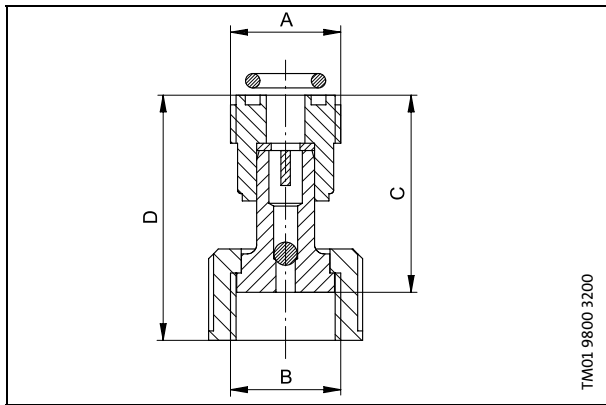

Pump type	Maximum Pressure [psi (bar)]	Dimensions				Material number
		A	B	C [in (mm)]	D [in (mm)]	
DME, DMS	145 (10)	M30 x 3.5	M30 x 3.5	1.73 (44)	2.17 (55)	96446763
DMM 4 to DMM 23	145 (10)	G 5/8	Rp 5/8	1.62 (41)	2.01 (51)	96446761
DMM 48 to DMM 72	145 (10)	G 3/4	Rp 3/4	1.65 (42)	2.09 (53)	96446762

Multifunction valve

Compact valve unit for direct mounting on the pump discharge connection. The valve has four functions:

1. Constant counter pressure
2. Anti-siphoning
3. Pump protection
4. Manual pressure relief

Relief pressure: 160 psi (11 bar)
 Counter-pressure: 22 psi (1.5 bar)

Dimensions

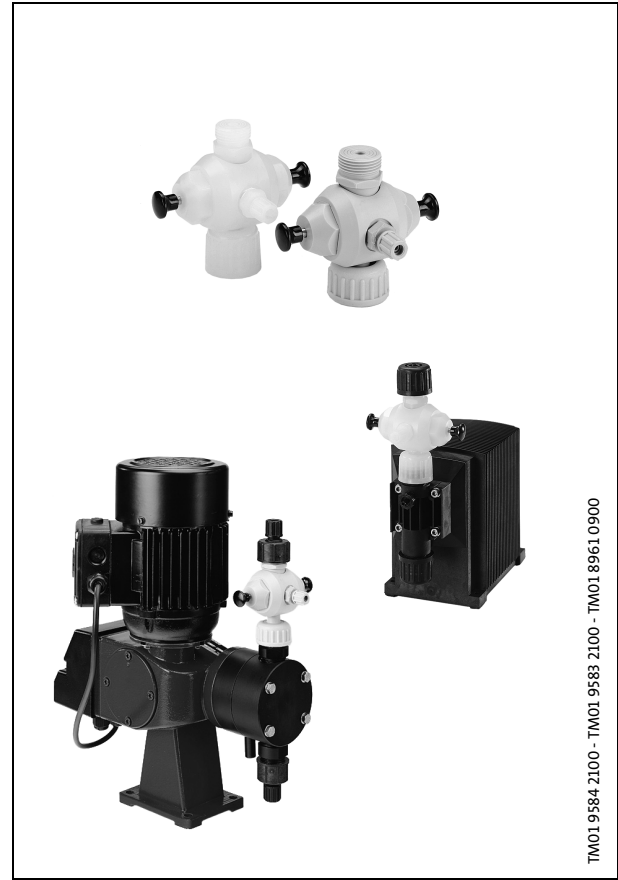
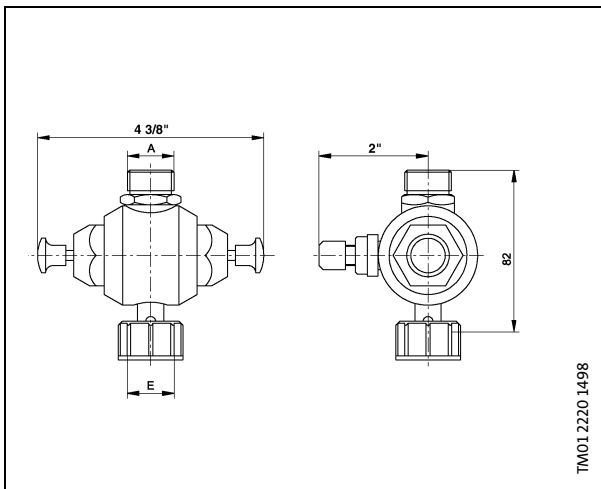

Pump Types	Materials			Product Number
	Housing	Gasket	Diaphragm	
DME, DMS*	PVDF	FKM	PTFE	96497411
	PP	EPDM	PTFE	96440584
		FKM	PTFE	96440585
	PVC	EPDM	PTFE	96496470
		FKM	PTFE	96446752
PVDF	FKM	PTFE	96440586	
DMM 4 DMM 8 DMM 15 DMM 23	PP	EPDM	PTFE	96440590
		FKM	PTFE	96440591
	PVDF	FKM	PTFE	96440592
	PVC	FKM	PTFE	96446754
DMM 48 DMM 72	PP	EPDM	PTFE	96440587
		FKM	PTFE	96440588
	PVDF	FKM	PTFE	96440589
	PVC	FKM	PTFE	96446753

*Fits stainless steel pump heads

Quick Guide

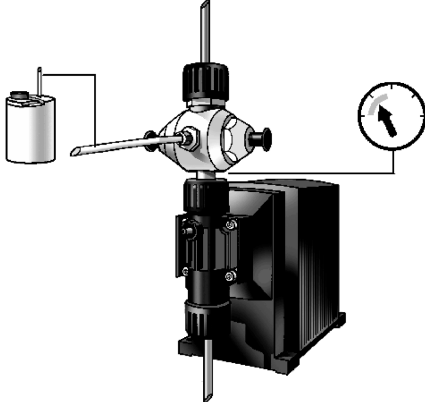
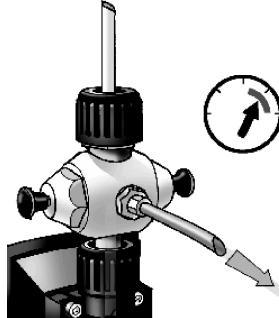
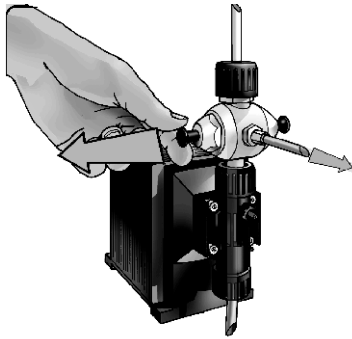
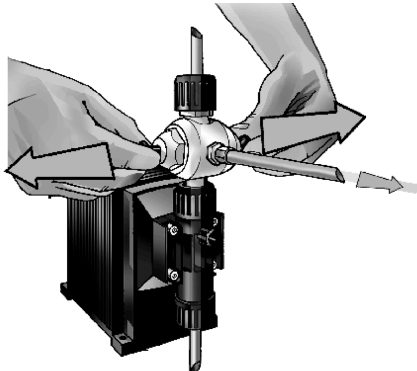
Multifunction valve	Description
 <p style="text-align: right; font-size: small;">TM02 0092 3800</p>	<ul style="list-style-type: none"> Constant counter pressure The valve keeps the counter pressure constant at 22 psi (1.5 bar) to optimize the dosing accuracy when dosing into systems with fluctuating pressure or pressure-less systems. The valve prevents undesired siphoning when the pump inlet pressure is higher than or equivalent to the discharge pressure.
 <p style="text-align: right; font-size: small;">TM02 0093 3800</p>	<ul style="list-style-type: none"> Pump protection The valve protects the pump against excessive pressure by releasing the pressure in the dosing head when the discharge pressure exceeds 160 psi (11 bar).
 <p style="text-align: right; font-size: small;">TM02 0094 3800</p>	<ul style="list-style-type: none"> Manual pressure relief When the left knob is pulled, the pressure in the dosing head is relieved for priming or degassing.
 <p style="text-align: right; font-size: small;">TM02 0095 3800</p>	<ul style="list-style-type: none"> Manual pressure relief When both knobs are pulled at the same time, the dosing head and the discharge tube are relieved.

Dosing monitor

The dosing monitor is designed to monitor the dosing of liquids which may cause gas accumulation in the dosing head, thus stopping the dosing process even if the pump is still operating.

For every measured dosing stroke, the dosing monitor gives a pulse signal to the level input so that the pump can compare performed pump strokes (from internal stroke sensor) with externally measured physical strokes (from the dosing monitor). If an external dosing stroke is not measured together with the internal dosing stroke, this is considered a fault that may have been provoked by empty tank or gas in the dosing head.

When used together with a DME pump, the monitor will only operate if it is mounted on the suction side of the pump.

When used together with a DMS pump, the monitor will also operate if it is mounted on the discharge side of the pump.

The dosing monitor should be connected to the level input (pin 2 and 3). Please reference page 31 for the wiring diagram. This input must be configured to the dosing monitoring. Consequently, it cannot be used as level input.

Once the input has been set for dosing monitoring and a dosing monitor has been connected and set, the dosing monitoring function will be active.

Definitions:

- Correct dosing stroke: A pulse from the dosing monitor corresponds to the internal stroke signal within acceptable time.
- Incorrect dosing stroke: There is no pulse from the dosing monitor corresponding to the internal stroke signal within the acceptable time (the pump is not pumping).

Logic

If two incorrect dosing strokes are performed, the pump will continue operating, but it will change over to alarm mode, like in case of “low level.” The red indicator light will be on and the alarm output, if any, will be activated (variant AR).

For each correct stroke the counter is reset and the alarm output, if any, is deactivated.

Operation in connection with vent valve:

It is possible to achieve a self-acting solution for liquids which may cause gas accumulation by using an automatic vent valve (see page 62) together with the dosing monitor and an alarm output (control variant AR). The alarm output can thus activate the vent valve, which will automatically vent gas accumulated in the dosing head. When the dosing head has been vented, the pump will start pumping again.

The alarm output will be deactivated and the vent valve will close.

The dosing monitor is used in connection with the dosing monitoring function in DME, DMS-A, and DMS-AR pumps.

The monitor sends a pulse signal (closed contact) for every measured pump stroke in the dosing tube.

As the DME pump in many situations operates without pulsations in the discharge side, the monitor always must be installed on the suction side.

With the DMS pump, the monitor can be installed on both suction and discharge side.

- Max. pressure: 145 psi (10 bar)
- Max. liquid temperature: 95°F (35°C)
- Max. liquid viscosity: 20 cp (20 mPas)
- Pulse transmitter (reed contact) max. load: 48 VAC/VDC, 0.5 A
- Materials in contact with liquid: PMMA/PVC/PVDF/FKM

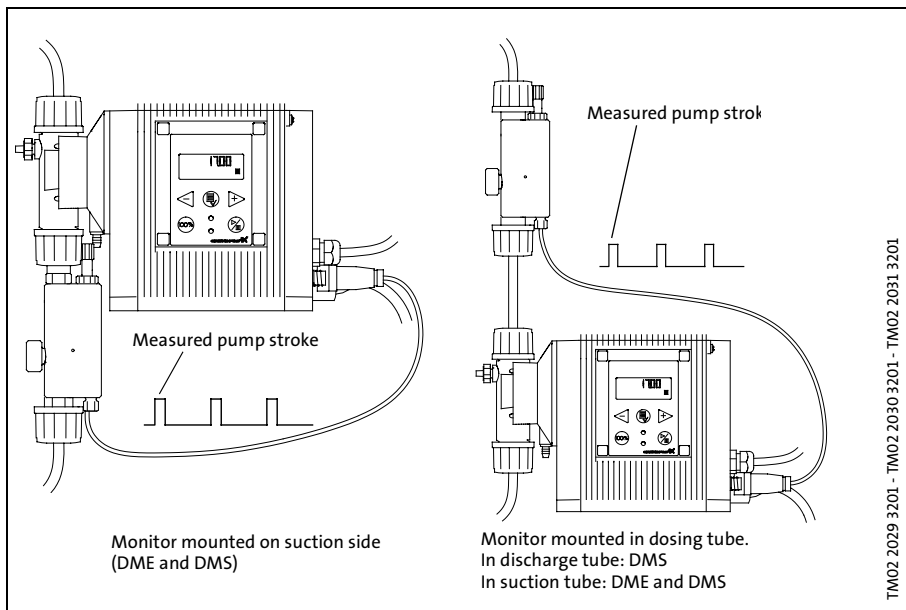

Model	Inner/Outer Tubing Diameter [in]	Connection Type	Material Number
PMMA/PVDF In-line	0.17 x 0.25", 0.25 x 0.375", 0.375 x 0.5"	Tubing	96470726
PMMA/PVDF Suction	-	-	96470724

Adaptor connections

The adaptor connections are used for adapting DME and DMS pump to suction and discharge tubing sizes other than Grundfos standard tubing sizes.

Each product number includes a complete set of two cones and two cutting rings, without unions.



TM02 2470 4401

Inner/outer tubing diameter	Material	Material number
0.17"/0.25"	PP	96460438
	PVDF	96460439
0.25"/0.375"	PP	96460443
	PVDF	96460444
0.375"/0.5"	PP	96460445
	PVDF	96460446

Level control unit

For dosing pumps with level control input, complete with level sensors (NO), ceramic weight, cable and plug for pump connection.

- Material: PVC.
- Level cable length: 8.2 ft (2.5 m).
- Level plug type: M12, 4-pole.
- Maximum load of level contacts: 50 V, 0.5 A.
- Function of level contacts: Low level/empty tank = closed contact.
- Product number: 96440539.



TM01 9587 2100

Dimensions

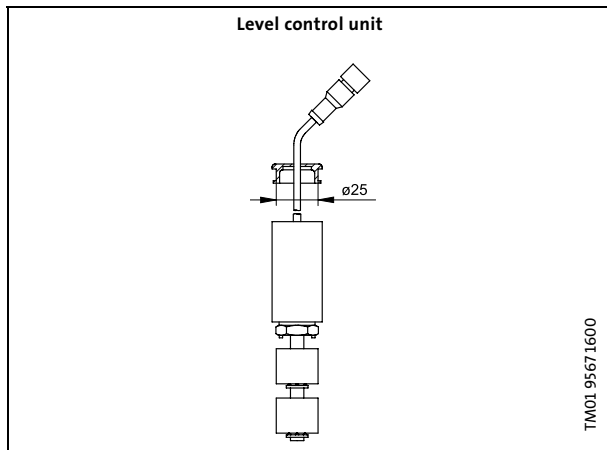

Rigid suction line

The reassembled line is adjustable for use on various tank depths. The suction line consists of foot valve with strainer, rigid suction pipe, tank connection thread and suction tubing.

For control variant A, the suction line is available with level sensors NO (Normally Open) for warning and empty-tank signals, supplied complete with cable and plug for pump connection.

- Material: PVC.
- Suction tubing length: 5 ft (1.5 m).
- Level cable length: 5 ft (1.5 m).
- Level plug type: M12, 4-pole.
- Maximum load of level contacts: 50 V, 0.5 A.
- Function of level contacts: Low level/empty tank = closed contact.
- PE screw cap: 15/16 in (33.5 mm):
- Product number: 96483418



TM01.9288.1600 - TM02.4551.1102

Dimensions

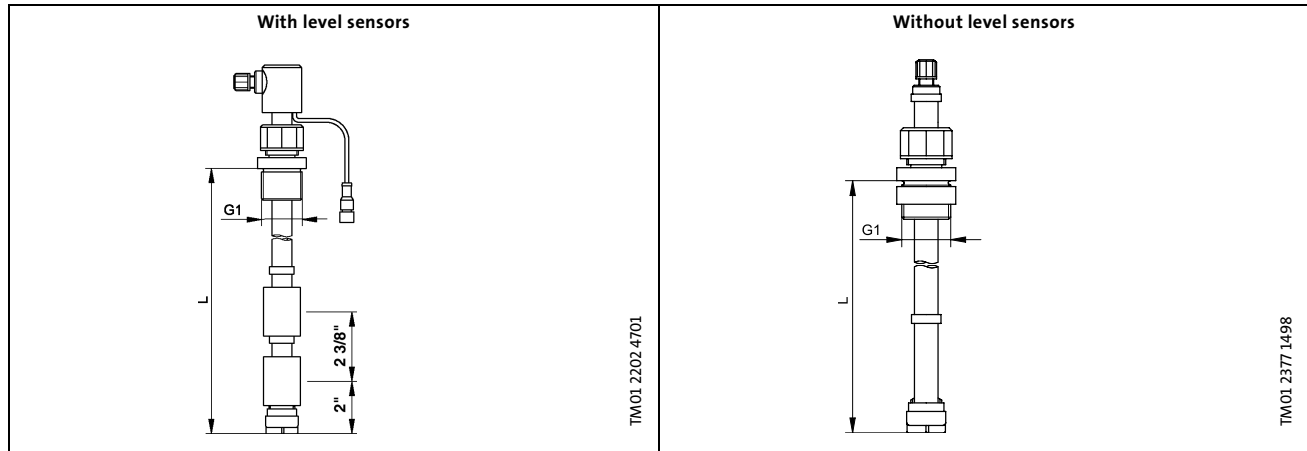

TM01.2202.4701

TM01.2377.1498

Inner/Outer Tubing Diameter [in]	Dual Level Control	Maximum Length [in (m)]	Grundfos Tank Size [g (l)]	Material Number
0.25 x 0.375	Y	44.25 (1124)	132 (500)	96479973
0.25 x 0.375	Y	21.25 (540)	16 (60)	96479974
0.25 x 0.375	Y	31.5 (800)	53 (200)	96479975
0.375 x 0.5	Y	44.25 (1124)	132 (500)	96479999
0.375 x 0.5	Y	35.4 (900)	79 (300)	96480000

Back pressure and relief valve

Adjustable valve for installation in the discharge tube.

- Installed in-line, the valve works as a counter-pressure valve optimizing dosing accuracy into systems with fluctuating pressure or as anti-siphoning valve when dosing into pressureless systems.
- Installed in a T-connection with the valve outlet connected to the tank, the valve works as a pressure relief valve or a safety valve, protecting the pump and the discharge line against excessive pressures.

Pressure range: 0-145 psi (0-10 bar).

Diaphragm material: PTFE.



TM01 9289 1600

Back pressure and relief valve	Description
<p style="text-align: center;">145 psi 0 psi</p> <p style="text-align: right; font-size: small;">TM02 0096 3800</p>	<ul style="list-style-type: none"> • In-line installation The valve functions as a back pressure valve optimizing dosing accuracy into systems with fluctuating pressure or as antisiphoning valve when dosing into pressureless systems.
<p style="text-align: center;">145 psi 0 psi</p> <p style="text-align: center;">p2 p1</p> <p style="text-align: right; font-size: small;">TM02 0097 3800</p>	<ul style="list-style-type: none"> • T-connection installation If the valve outlet is connected to the tank, the valve functions as a pressure relief valve or a safety valve, protecting the pump and the discharge tube against excessive pressures. Pressure range: 0 - 145 psi (0 - 10 bar).
<p style="text-align: center;">p2 p2 < p1</p> <p style="text-align: center;">p2 p2 > p1</p> <p style="text-align: right; font-size: small;">TM02 0098 3800</p>	<ul style="list-style-type: none"> • p2 < p1 When the pressure p2 is lower than the pressure p1, the pumped liquid will be pumped to the installation. • p2 > p1 When the pressure p2 is higher than the pressure p1, the pumped liquid will be pumped back to the tank.

Dimensions, without connectors

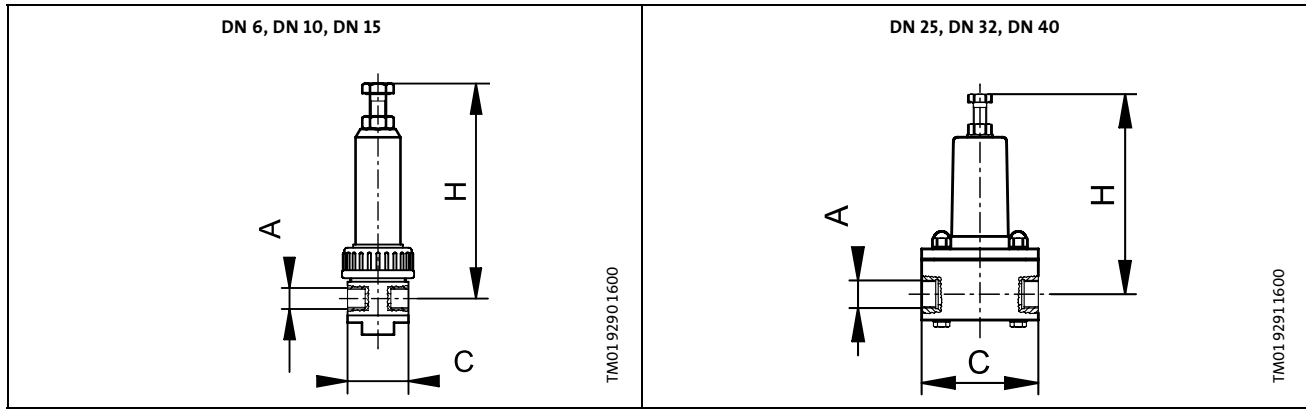

Size	Maximum flow rate [g/h (l/h)]	Dimensions			Housing material	Connections		Product number
		A	C [mm]	H [mm]		Type	Inner/outer tubing or pipe diameters/thread	
DN 6	6.6 (25)	1/4"	40	142	PVC	Tubing	0.17" / .25"	96487951
							.25" / .375"	96487906
							.25" / .5"	96487905
						Inner thread	- / .25" NPT	96487950
					PVDF	Tubing	0.17" / .25"	96487908
							.25" / .375"	96487972
	.25" / .5"	96487970						
	Inner thread	- / .25" NPT	96487907					
	316 AISI Stainless steel	Inner thread	- / .25" NPT	96487973				
DN 10	19.8 (75)	3/8"	55	147	PVC	Tubing	.25" / .375"	96487899
							Inner thread	- / .375" NPT
					PVDF	Tubing	.25" / .375"	96487941
							Inner thread	- / .375" NPT
						316 AISI Stainless steel	Inner thread	- / .375" NPT
DN 15	55.5 (210)	1/2"	75	152	PVC	Inner thread	- / .375" NPT	96487943
					PVDF	Inner thread	- / .375" NPT	96487944
					316 AISI Stainless steel	Inner thread	- / .375" NPT	96487945
DN 25	103 (390)	1"	140	240	PP	Inner thread	- / .5" NPT	96487897
							Inner thread	- / 1" NPT
						316 AISI Stainless steel	Inner thread	- / 1" NPT
DN 32	169 (640)	1 1/4"	140	242	PP	Inner thread	- / 1.25" NPT	96487948
DN 40	261 (990)	1 1/2"	152	252	PP	Inner thread	- / 1.5" NPT	96487949

Valve assembly

Complete assembly of either:

- back pressure and relief valve or
- relief and shut-off valve.

Back pressure and relief valve

The pump discharge line is connected between the two valves. One valve works as a counter-pressure valve optimizing dosing accuracy when dosing into systems with fluctuating pressure or as anti-siphoning valve when dosing into pressureless systems.

The outlet of the other valve is connected to the tank, and the valve thus works as a pressure relief valve or a safety valve protecting the pump and the discharge line against excessive pressures.

Relief and shut-off valve

The pump discharge line is connected between the two valves. The outlet of the counter-pressure valve is connected to the tank, and the valve thus works as a pressure relief valve or a safety valve protecting the pump and the discharge line against excessive pressures.

The shut-off valve can be used for interrupting the dosing temporarily without stopping the pump. If the shut-off valve is closed, the relief valve will return the dosed liquid to the tank.

Valve diaphragm material: PTFE.

Pressure range of counter-pressure and relief valve:
 0 - 145 psi (0-10 bar).



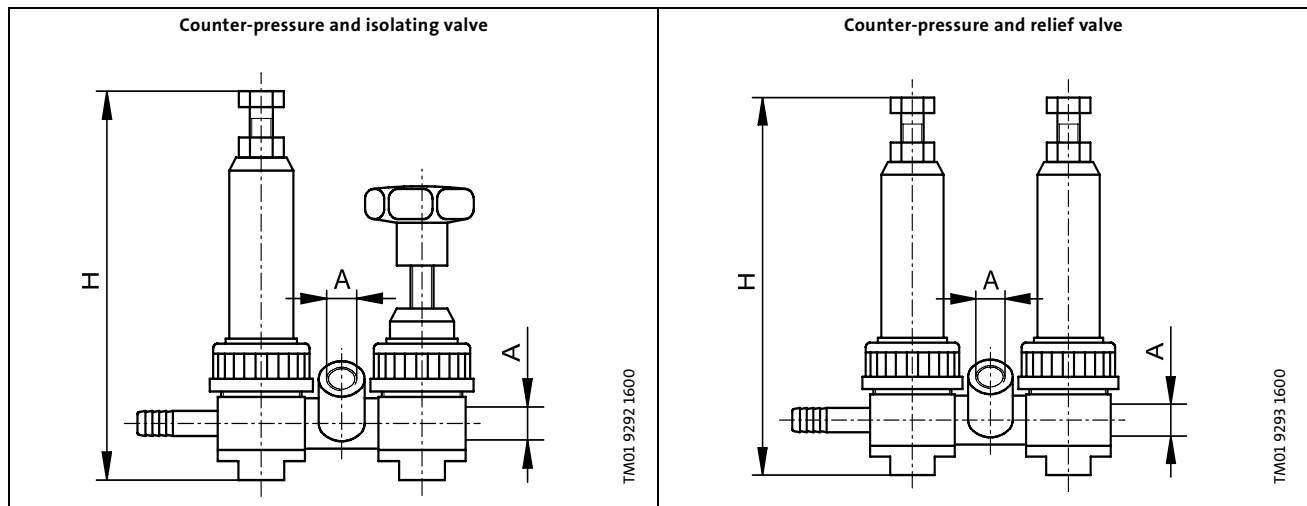

TM01 9588 2100

Dimensions

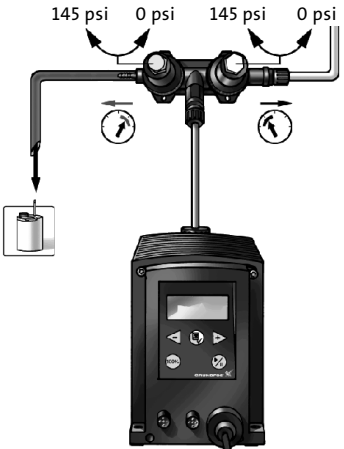

Quick Guide

Valve assembly	Description
 <p style="text-align: center;">145 psi 0 psi 145 psi 0 psi</p> <p style="text-align: right; font-size: small;">TM02 0099 3800</p>	<ul style="list-style-type: none"> Back pressure and relief valve The pump discharge tube is connected between the two valves. One valve functions as a counter pressure valve optimizing dosing accuracy when dosing into systems with fluctuating pressure. The outlet of the other valve is connected to the tank, and the valve thus functions as a pressure relief valve or a safety valve protecting the pumps and the discharge tube against excessive pressures.
 <p style="text-align: center;">145 psi 0 psi close open</p> <p style="text-align: right; font-size: small;">TM02 0100 3800</p>	<ul style="list-style-type: none"> Relief and isolating (shut-off) valve The pump discharge tube is connected between the two valves. The outlet of the relief valve is connected to the tank, and the valve thus functions as a pressure relief valve or a safety valve protecting the pump and the discharge tube against excessing pressures. The isolating valve can be used for interrupting the dosing temporarily without stopping the pump. If the isolating valve is closed, the relief valve will return the dosed liquid to the tank.

Automatic vent valve

Automatic vent valve for direct fitting to the pump discharge connection.

- Valve housing material: PMMA/PVC.
- O-ring material: FKM.
- Valve ball material: Glass.
- Valve seat material: PVDF.
- Power cable length: 4.9 ft (1.5 m).

The valve is available either with or without timer.

With timer:

The valve is continuously connected to the power supply and the opening time and opening intervals are set on the timer.

Without timer:

The valve will open when power is connected to the valve. This version is ideal for operation in connection with a dosing monitor.



TM01.9591.2100 - TM01.9592.2100

Dimensions (with timer)

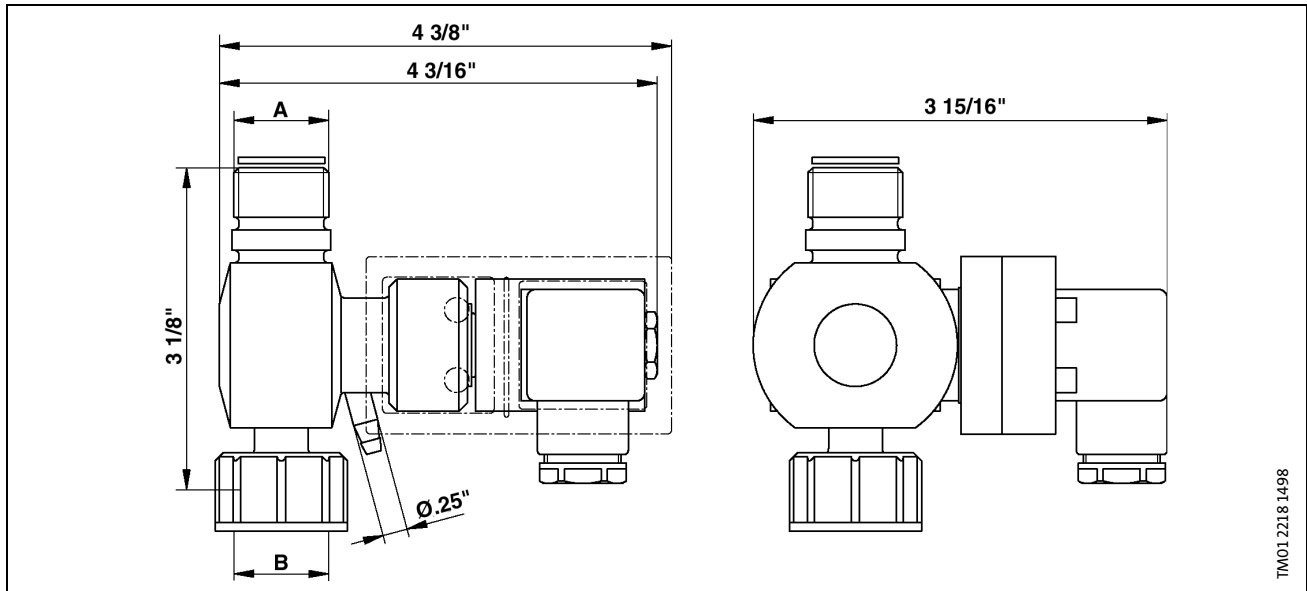

TM01.2218.1498

Pump type	Dimension A + B	Voltage	Power plug	Material number	
				With timer	without timer
DME, DMS	M30 x 3.5	1 x 120 V, 50-60 Hz	US	96441084	96471086

Quick Guide

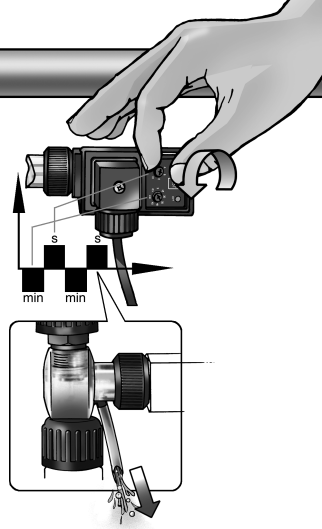
Automatic vent valve	Description
 <p style="text-align: right; font-size: small;">TM02 0191 3800</p>	<ul style="list-style-type: none"> Function (with timer) The valve automatically vents the dosing head when dosing continuously gassing liquids. A non-return valve prevents liquid from flowing back from the discharge tube during the venting phase. The outlet hose of the vent should be connected to the tank. The valve is supplied with power cable and plug. Venting duration and intervals can be set by means of an integrated timer, see below.
 <p style="text-align: right; font-size: small;">TM02 0102 3800</p>	<ul style="list-style-type: none"> Setting (with timer) The valve opening time (see picture at left) is set in seconds by means of the button "S". The intervals are set in minutes by means of the button "min."

Pulsation dampener

The pulsation dampener can be installed both in the suction and the discharge line for reducing pressure surges, thereby ensuring a steady flow. The dampener is particularly suitable for long discharge lines and/or lines with a small diameter.

Installed in the discharge line, the dampener can be used to optimize dosing accuracy and to protect the pump and discharge line against pressure surges. Depending on the system pressure, it may be necessary to install a counter-pressure valve after the dampener to optimize its function.

Maximum pressure: 145 psi (10 bar)

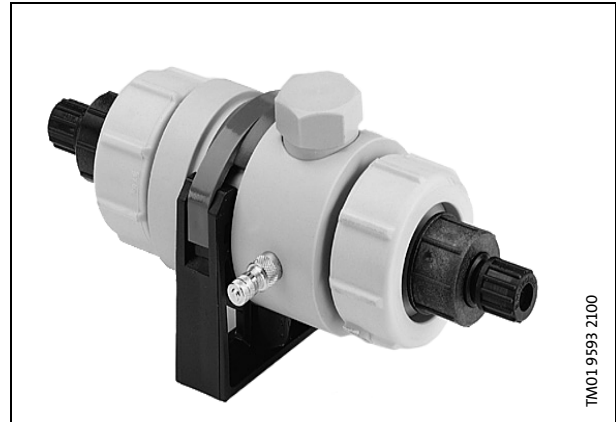

Dimensions, without connections

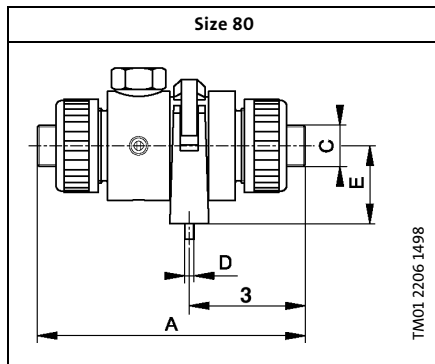

Size	Maximum flow rate [gph]	Materials		Connections		Dimensions [mm]				Product number
		Housing	Diaphragm	Type	Inner/outer tubing or pipe diameters/thread [in]	A [in]	C	D	E [in]	
80	19	PP	CSM	Tubing	0.25 x 0.375	6 13/16	G ¼	M6	2	96479971
		PVC	FKM	Tubing	0.25 x 0.375					96479972

Pulsation dampener	Description
	<ul style="list-style-type: none"> Setting The pressure in the pulsation dampener is set by means of compressed air. The pressure must be: system pressure (p_1) x 0.6. <p>The pressure on the liquid-side of the pulsation dampener should be 0 when the air-side is filled with air. This applies both to the initial setting of the pressure as well as to later checkups.</p> <p>To facilitate the reading of the pulsation dampener pressure, a pressure gauge can be fitted directly on the dampener. The pressure gauge is shown under accessories for pulsation dampeners.</p>

Accessories for pulsation dampeners

Connector

For direct mounting of pulsation dampener size 80 to pump discharge connection.

Pump type	A [in]	B	C [in]	Product number
DME DMS	Rp 3/4"	M30	15/16	96441089
DMM 4 DMM 8 DMM 15 DMM 23	Rp 3/4"	G 5/8	15/16	96441088
DMM 48 DMM 72	Rp 3/4"	G 3/4	13/16	96441087

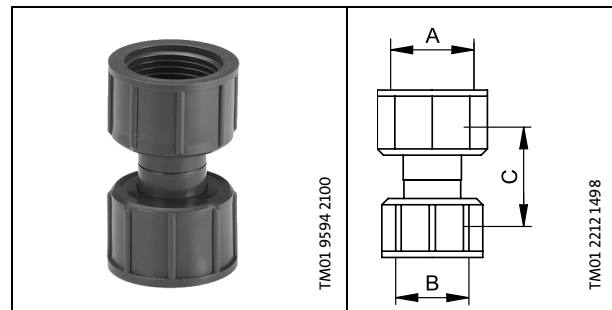

Dummy plug

For installation of pulsation dampener in T-piece connection.

Pulsation damper size	Dimension [in]	Product number
	A	
80	Rp 3/4"	96441092

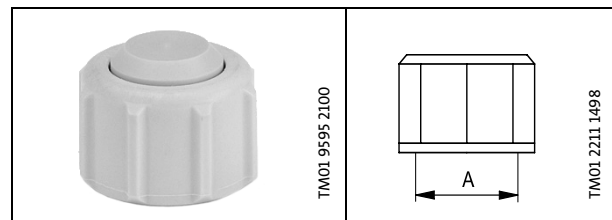

Pressure gauge

For measuring gas pressure in pulsation dampener.

Pressure range	Product number
0-6 bar	96441096
0-16 bar	96441095

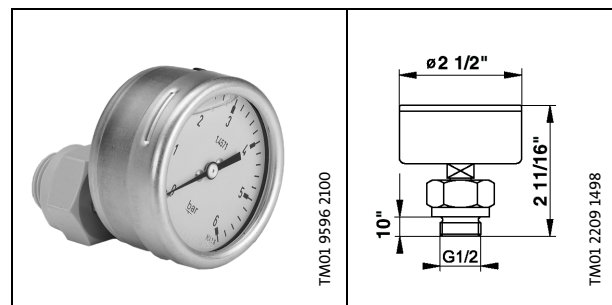

Priming aid

The priming aid is a transparent, air-tight collector with a screw cap on top. It is mounted between the tank and the pump. The inlet from the tank and the outlet to the pump are both in the bottom of the collector.

Both a bracket for wall mounting and a rod for mounting on top of a tank are included.

The priming aid has the following functions:

- **Priming.**
To facilitate priming in case of frequent stops and/or high suction lifts by eliminating or reducing the dry-suction phase.
- **Gas trap.**
Gas occurring in the suction line is trapped in the top of the priming aid to prevent it from entering the pump head.
- **Pulsation dampening.**
The dampening gas cushion in the top of the priming aid reduces pressure surges, resulting in optimum dosing accuracy and reduced risk of cavitation.

Material: PVC.

Dimensions



TM01 9597 2100

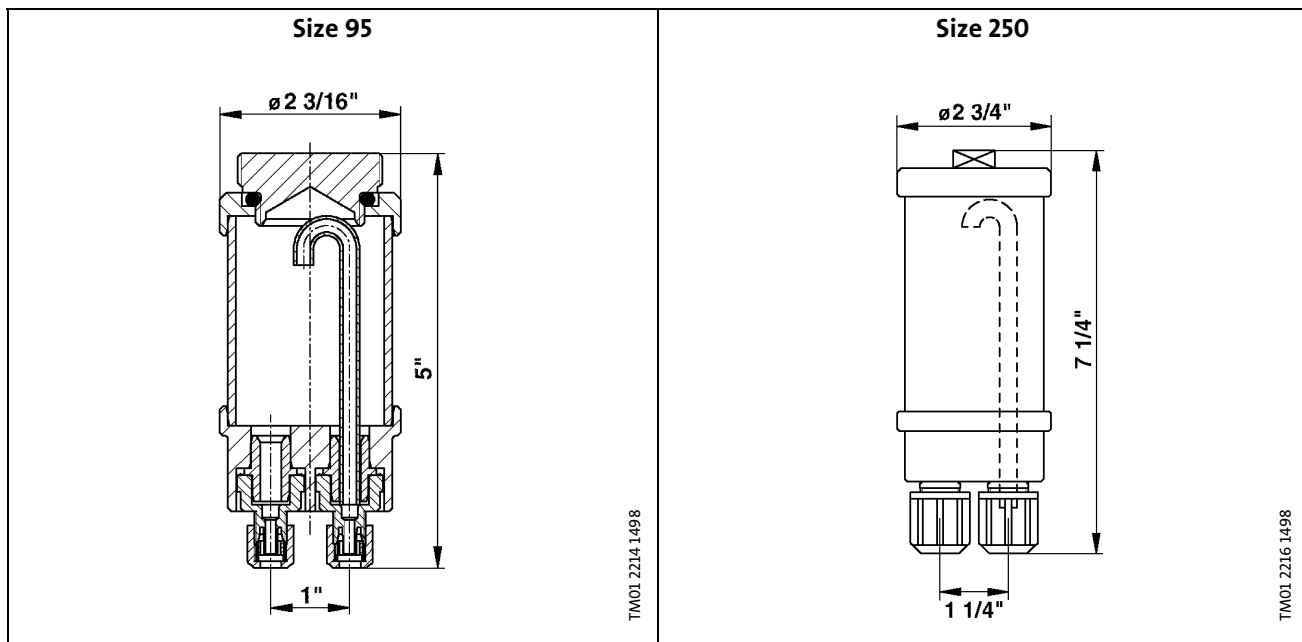



TM01 2214 1498

TM01 2216 1498

Model	Inner/Outer Tubing Diameter [in]	Priming Capacity [gal]	Connection Type	Material Number
Kit, priming aid, 95 0.25 x 0.375"	0.25 x 0.375	0.025	Tubing	96479970
Kit, priming aid, 250 0.25 x 0.375"	0.25 x 0.375	0.066	Tubing	96480690

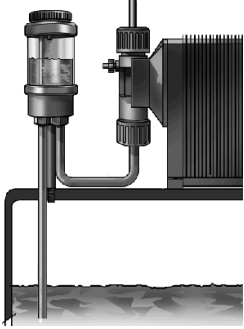
Quick Guide

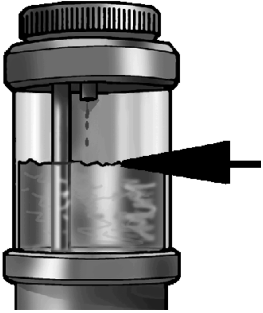
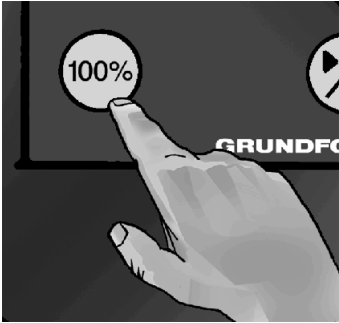
Priming aid	Description
 <p style="text-align: right; font-size: small;">TM02.0104.3800</p>	<ul style="list-style-type: none"> Installation The priming aid is mounted between the tank and the pump. Here it is shown with a rod for mounting on top of the tank.
 <p style="text-align: right; font-size: small;">TM02.0105.3800</p>	<ul style="list-style-type: none"> Priming Pour pumped liquid into the priming aid...
 <p style="text-align: right; font-size: small;">TM02.0106.3800</p>	<p>...to the level shown</p>
 <p style="text-align: right; font-size: small;">TM02.0107.3800</p>	<ul style="list-style-type: none"> DME and DMS pumps Press the maximum capacity button

Tank

Closed cylindrical tank with screw cap and bush for rigid suction line.
 Material: PE.

Pump mounting plate:

The pumps can be mounted directly on the tank top by means of adapter plates.

DME 2 to DME 12 and DMS: 96446765.
 DME 19 and DME 48: 96446766.
 DMM 4 to DMM 155: 96457099.

Floor mounting bracket:

Set of four: 96446767.



Dimensions

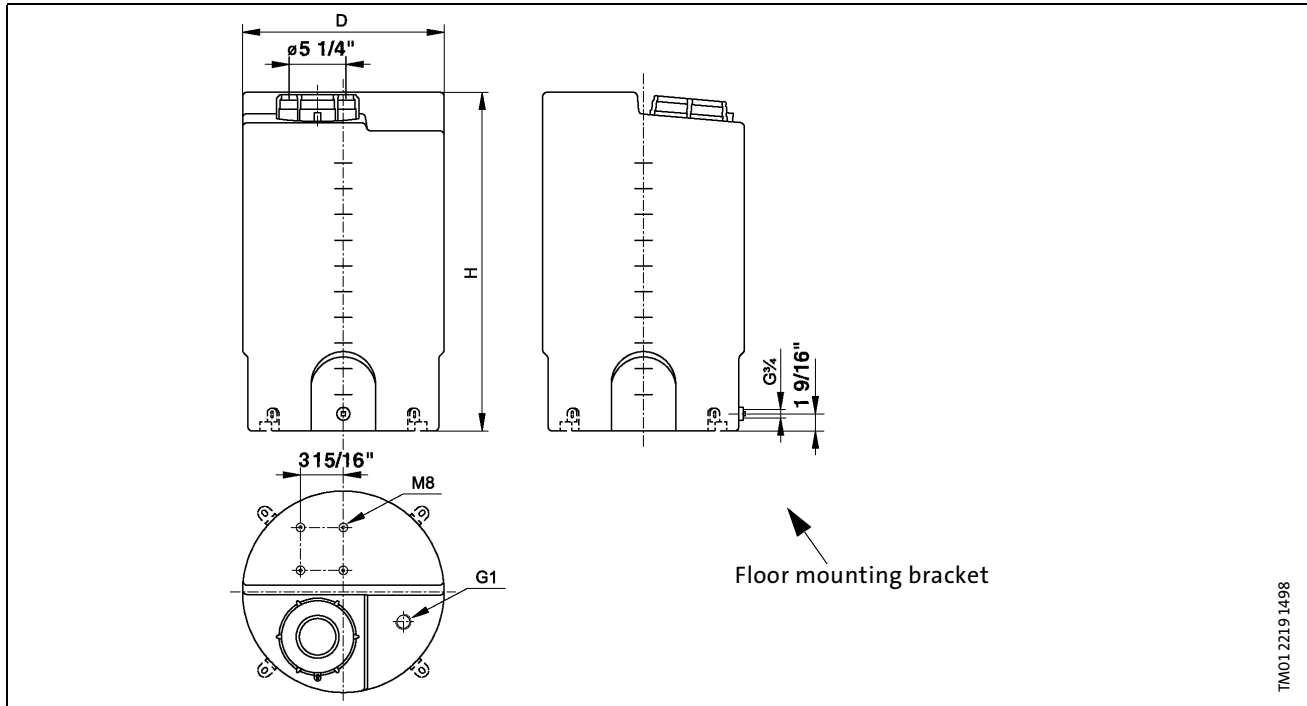

Tank size [g (l)]	Dimensions [in]		Weight [lb]	Product number
	D	H		
16 (60)	16 3/8	22 11/16	10	96467256
26 (100)	18 1/2	31 7/16	15.5	96467257
53 (200)	23 5/8	33 5/16	28.5	96467258
79 (300)	26 5/8	37 7/16	6.8	96467259
132 (500)	32 1/8	42 9/16	12.2	96467330
264 (1000)	42 9/16	53 1/2	17.7	96471403

26 Gallon (100 liter) tank

Closed square tank with screw cap and mounting platform for a single or parallel pump mounting.

The pump mounting platform is raised above the screw cap to protect pumps and connections when filling chemicals into the tank.

The height difference also allows for direct mounting of the dosing monitor on the suction side.

Material: MDPE.
 Max. material temperature: +122°F (+50°C).
 Liquid temperature: Minimum: -4°F (-20°C).
 Maximum: 113°F (+45°C).

Mounting platform

DME and DMS pumps can be fitted directly on the platform by means of brass inserts molded into the platform.

Mounting combination

Single or parallel mounting of DME and DMS pumps.

Material thickness: 3/16" (4mm)



Tank size [g (l)]	Material number
26 (100)	96489271

Dimensions

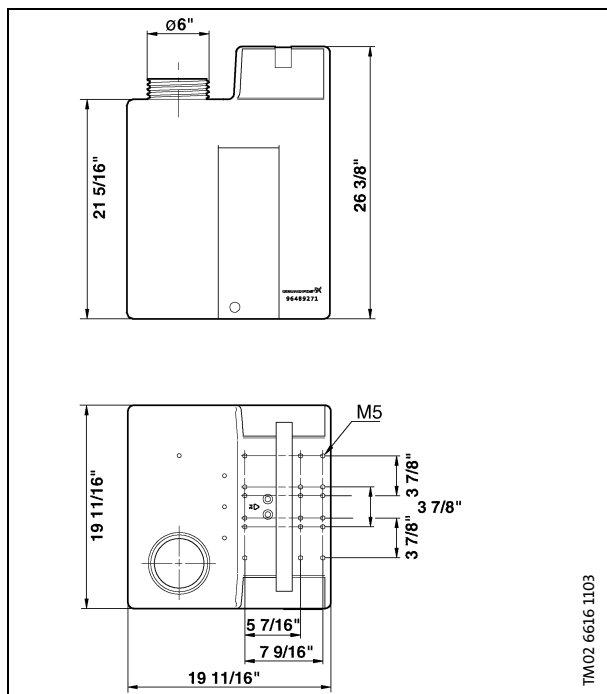

Wall bracket

Wall brackets for easy installation of the dosing pump on the wall.

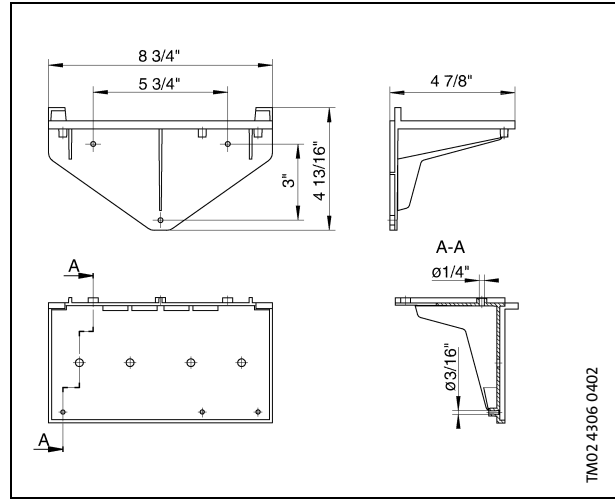

Model	Pump Types	Material	Material Number
Wall bracket DME/DMS	DME, DMS	PPO	96441202

Note: This form is available as a spreadsheet in the database Grundfos Technical Information.
The information marked * must be provided.

Company name: _____

Customer name: _____

Address: _____

Telephone: _____

E-mail address: _____

Main application: _____



TM02 0002 3800

1. Pump data

- 1.a Required capacity* _____ g/h
- 1.b Required counter pressure* _____ psi
- 1.c Required power supply* _____ V/Hz
- 1.d Installation*
- Wall
 - Floor

2. Version required

- 2.a Control panel position*
- S = side-fitted
 - F = front-fitted

3. Application

- Cooling tower
- Boiler
- Swimming pool
- Primary & process water (for industrial application)
- Biological wastewater & sewage treatment
- Drinking water treatment
- Irrigation

3.a OEM application

- Car wash
- Mechanical component wash
- Surface plating
- Other (please specify)

4. Liquid to be injected

- 4.a Type of liquid* _____
- 4.b Commercial name _____
- 4.c Concentration* _____
- 4.d Specific weight _____
- 4.e Viscosity at normal liquid temperature* _____
- 4.f Viscosity at lowest liquid temperature _____
- 4.g Does it contain solid particles* Yes No
- If yes, size of particles: _____
- 4.h Does the liquid have phenomena such as:
- Crystalization
 - Precipitation
 - Gasification

5. Use and environmental conditions*

5.a Injection place

- Open reservoir
- Pipeline

5.b Pressure in the pipeline

Min. _____ bar
Max. _____ bar

5.c Max. temperature at the injection point _____ ° F

5.d Max. ambient temperature _____ ° F

5.e Suction lift _____ ft

5.f Length of suction line _____ ft

5.g Length of discharge line _____ ft

6. Application details*

6.a Quantity to be dosed

In ppm, % or ml/l of a 100% concentration or a solution: _____

Example: 10 ml/l of chlorine or 10 ml/l of a 5% solution, the latter meaning that 200 ml/l must be dosed to achieve the correct dosage.

7. External pump control*

7.a Pump control

- Manual
- Water meter
- Controller
 - pH
 - Redox (ORP)
 - Chlorine
 - Conductivity
 - Other (please specify) _____

7.b Bus communication: _____

7.c Supplementary options

- Alarm relay
- Level control

8. Accessories required (see details in the data booklet)

<input type="checkbox"/> 1. Installation kit pos. 3 + 4 + 5
<input type="checkbox"/> 2. Control cable and plug
<input type="checkbox"/> 3. Tubing
<input type="checkbox"/> 4. Foot valve
<input type="checkbox"/> 5. Injection valve
<input type="checkbox"/> 6. Multifunction valve
<input type="checkbox"/> 7. Flow indicator
<input type="checkbox"/> 8. Pump connection (retro fitting)
<input type="checkbox"/> 9. Rigid suction line
<input type="checkbox"/> 10. Level control unit
<input type="checkbox"/> 11. Counter-pressure and relief valve
<input type="checkbox"/> 12. Counter-pres. and isolating valve
<input type="checkbox"/> 13. Automatic vent valve
<input type="checkbox"/> 14. Pulsation dampener <input type="checkbox"/> Connector <input type="checkbox"/> Dummy plug <input type="checkbox"/> Pressure gauge
<input type="checkbox"/> 15. Priming aid
<input type="checkbox"/> 16. Tank <input type="checkbox"/> Hand mixer <input type="checkbox"/> Electric agitator
<input type="checkbox"/> 17. Water meter

Subject to alterations.

This page intentionally left blank.